



Operating Instructions

**surfaceCONTROL 3D SC2500 / SC2510**

SC2500-300  
SC2510-300  
SC2500-400  
SC2510-400  
SC2500-575  
SC2510-575

MICRO-EPSILON  
MESSTECHNIK  
GmbH & Co. KG  
Koenigbacher Str.15

94496 Ortenburg/Germany

Tel. +49 (0) 8542 / 168-0  
Fax +49 (0) 8542 / 168-90  
e-mail [info@micro-epsilon.com](mailto:info@micro-epsilon.com)  
[www.micro-epsilon.com](http://www.micro-epsilon.com)

# Contents

<b>1.</b>	<b>Safety</b> .....	<b>5</b>
1.1	Symbols Used .....	5
1.2	Warnings .....	5
1.3	Notes on CE Marking .....	6
1.4	Intended Use .....	6
1.5	Proper Environment.....	6
<b>2.</b>	<b>Light Source</b> .....	<b>7</b>
<b>3.</b>	<b>Functional Principle, Technical Data</b> .....	<b>8</b>
3.1	Short Description .....	8
3.1.1	Measuring Principle.....	8
3.1.2	System Design .....	8
3.1.3	Particular Performance Characteristics .....	8
3.2	Technical Data .....	9
3.3	Control and Indicator Elements.....	10
<b>4.</b>	<b>Delivery</b> .....	<b>12</b>
4.1	Unpacking/Included in Delivery .....	12
4.2	Storage .....	12
<b>5.</b>	<b>Installation and Assembly</b> .....	<b>13</b>
5.1	Sensor.....	13
5.2	Mounting Adapter.....	16
5.3	SC2500 Controller .....	17
5.4	Electrical Connections.....	18
5.4.1	Connection Diagram .....	18
5.4.2	surfaceCONTROL 3D 2500 Sensor.....	18
5.4.2.1	General.....	18
5.4.2.2	Supply Voltage (Power) .....	18
5.4.2.3	Sensor Control (USB) .....	19
5.4.2.4	Image Data Transmission (Gigabit Ethernet) .....	19
5.4.3	surfaceCONTROL 3D 2500 Controller .....	20
5.4.3.1	General.....	20
5.4.3.2	Supply Voltage (Power) .....	20
5.4.4	Gigabit Ethernet Connection.....	21
5.5	Installation Instructions .....	21
5.6	Initial Operation.....	22
<b>6.</b>	<b>Operation</b> .....	<b>23</b>
6.1	Turning On .....	23
6.2	Operating Programs .....	23
6.3	Installation.....	23
6.3.1	Requirements .....	23
6.3.2	Connecting surfaceCONTROL 3D 25x0 to the PC .....	24
6.4	Notes for Operation .....	24
6.4.1	Measurement Area .....	24
6.4.2	Calibration .....	24
6.4.3	Positioning of Sensor and Test Object.....	25
6.4.3.1	General.....	25
6.4.3.2	Alignment with Crosshair .....	25
6.4.4	Exposure.....	27
6.5	Interferences .....	28
6.5.1	Reflection Factor of the Surface of the Target.....	28
6.5.2	Color Differences .....	28
6.5.3	Temperature Influences.....	28
6.5.4	Ambient Light .....	28
6.5.5	Mechanical Vibrations .....	28
6.5.6	Surface Roughness and Texture .....	29
6.5.7	Shadowing Effects and Multiple Reflections.....	29
6.6	Cleaning.....	29
6.6.1	Housing .....	29
6.6.2	Protective glasses / Filter .....	29
<b>7.</b>	<b>Disclaimer</b> .....	<b>30</b>
<b>8.</b>	<b>Service, Repair</b> .....	<b>30</b>
<b>9.</b>	<b>Decommissioning, Disposal</b> .....	<b>30</b>
	<b>Appendix</b> .....	<b>31</b>
<b>A 1</b>	<b>Accessories</b> .....	<b>31</b>
<b>A 2</b>	<b>Optional Accessories</b> .....	<b>31</b>
A 2.1	Drawings of Mounting Adapter.....	33
A 2.1.1	X95/Dovetail Mounting Adapter .....	33
A 2.1.2	47° Dovetail Mounting Adapter .....	33
<b>A 3</b>	<b>GenICam surfaceCONTROL Parameters</b> .....	<b>34</b>



## 1. Safety

System operation assumes knowledge of the operating instructions.

### 1.1 Symbols Used

The following symbols are used in these operating instructions:



Indicates a hazardous situation which, if not avoided, may result in minor or moderate injury.



Indicates a situation that may result in property damage if not avoided.



Indicates a user action.



Indicates a tip for users.

Measurement

Indicates hardware or a software button/menu.

### 1.2 Warnings



Do not look directly into the light source of the sensor.

- > Risk of injury, damage to the eyes and skin

Connect the power supply and the display/output device according to the safety regulations for electrical equipment.

- > Risk of injury
- > Damage to or destruction of the sensor



Avoid shocks and impacts to the sensor and the controller.

- > Damage to or destruction of the sensor and/or the controller

The supply voltage must not exceed the specified limits.

- > Damage to or destruction of the sensor

Avoid constant exposure of the sensor to dust or splashes of water by taking suitable measures such as blowing off or using a protective housing.

- > Damage to or destruction of the sensor

Do not touch the protective windows. Remove any fingerprints immediately using pure alcohol and a clean cotton cloth without leaving any streaks.

- > Failure of the measuring device

Protect the cables against damage.

- > Failure of the measuring device

The sensor housing may only be opened by authorized persons.

- > Damage to or destruction of the sensor

Only plug in or disconnect devices when disconnected from the power supply.

### 1.3 Notes on CE Marking

The following apply to the surfaceCONTROL 3D 25x0 measuring system:

- EU Directive 2014/30/EU
- EU Directive 2011/65/EU

Products which carry the CE mark satisfy the requirements of the EU directives cited and the relevant applicable harmonized European standards (EN). The measuring system is designed for use in industrial environments.

The EU Declaration of Conformity and the technical documentation are available to the responsible authorities according to the EU Directives.

### 1.4 Intended Use

- The surfaceCONTROL 3D 25x0 measuring system is designed for use in an industrial environment. It is used for
  - Non-contact optical measurement of diffuse reflective surfaces
  - Quality monitoring as well as form/position and surface inspection
- The sensor must only be operated within the limits specified in the technical data, see [Chap. 3.2](#).
- The sensor must be used in such a way that no persons are endangered or machines and other material goods are damaged in the event of malfunction or total failure of the sensor.
- Take additional precautions for safety and damage prevention in case of safety-related applications.

### 1.5 Proper Environment

- Protection class
  - Sensor, controller: IP40 (only applies in the case of connected output connectors and/or installed protective caps)

Optical paths during operation are excluded from the protection class. Contamination of the paths causes impairment or failure of the function.

The IP40 protection class is a specification that is limited to protection from dust and water. Oil, steam and emulsion effects are not included in this protection class and must be evaluated separately.

- Temperature range
  - Operation
    - Sensor: 5 ... +40 °C (+41 ... +104 °F)
    - Controller: -10 ... +60 °C (+14 ... +140 °F) <sup>1</sup>
  - Storage
    - Sensor: -10 ... +50 °C (+14 ... +122 °F)
    - Controller: -40 ... +85 °C (-40 ... 185 °F)
- Humidity: 20 ... 80 % (non-condensing)
- Ambient pressure: Atmospheric pressure

1) Max. permissible operating temperature with 0.7 m/s air blow

## 2. Light Source

The surfaceCONTROL 3D 25x0 sensor works with an LED lighting unit. Measurement is performed using blue light at the dominant 462 nm wavelength. The sensor is included in risk group 2 according to EN 62471: 2008.

---



Do not look into the lens. Consciously close your eyes or immediately turn away if the optical radiation enters the eye.

---

The warning sign below is attached to the front side:



*Fig. 1 LED warning sign*

- i** If the information sign is covered over when the unit is installed, the user must ensure that a supplementary information sign is attached at the installation location.

### 3. Functional Principle, Technical Data

#### 3.1 Short Description

##### 3.1.1 Measuring Principle

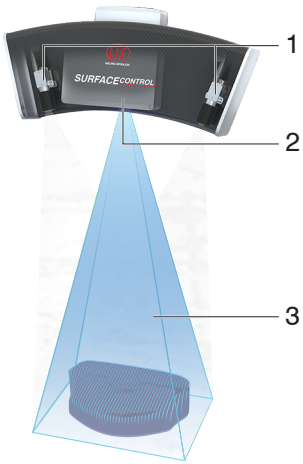

surfaceCONTROL 3D 25x0 is a sensor for non-contact and non-destructive optical and three-dimensional detection of components with diffuse reflective surfaces. It operates according to the optical triangulation principle (fringe projection):

- Using a matrix projector, a sequence of patterns is projected onto the test object surface.
- The light of the patterns diffusely reflected by the test object surface is recorded by two cameras.
- The three-dimensional surface of the test object is then calculated from the recorded image sequence and the arrangement of the two cameras to each other.

- 1 Cameras
- 2 Projection unit
- 3 Fringe light

Fig. 2 Measuring principle with sensor

##### 3.1.2 System Design



The surfaceCONTROL 3D 25x0 measuring system is composed of a compact sensor with a large measuring field and a controller. The captured 3D data is transferred to the external controller where they are processed.

Gigabit Ethernet ensures fast data output. The 2D/3D Gateway II supports EtherNet/IP, PROFINET and EtherCAT connections. 3DInspect and DefMap3D are powerful software tools that enable precise 3D measurements and surface inspection.

GigE Vision compatibility also allows easy integration into third-party image processing software. The comprehensive SDK for customer software integration rounds off the software package.

##### 3.1.3 Particular Performance Characteristics

- surfaceCONTROL 3D 25x0 is characterized by a compact design and highly accurate measurements while at the same time achieving high throughput of 3D points.
- Data are output via Gigabit Ethernet. GigE Vision compatibility allows the sensor to be integrated in different ways:
  - Software provided by Micro-Epsilon
  - Software by third parties
  - SDK
- Gigabit Ethernet as a fast default connection to the PC

System integrators, customers require their own software		User	
SC2500 	<ul style="list-style-type: none"> <li>- supported by 3DInspect</li> <li>- supported by Micro-Epsilon 3D Sensor SDK</li> <li>- supports GigE Vision</li> <li>- supported by DefMap3D (licensing via additional dongle!)</li> </ul>	SC2510 	<ul style="list-style-type: none"> <li>- Activation of the functional extension 3DInspect Automation</li> </ul>
		Micro-Epsilon software	



### 3.2 Technical Data

surfaceCONTROL 3D		SC2500-300	SC2510-300	SC2500-400	SC2510-400	SC2500-575	SC2510-575
Measurement area Length (x) * width (y) at distance (z)	Start	260 x 190 mm (475 mm)		350 x 260 mm (660 mm)		500 x 375 mm (950 mm)	
	Mid	300 x 220 mm (550 mm)		400 x 300 mm (760 mm)		575 x 435 mm (1100 mm)	
	End	340 x 250 mm (625 mm)		450 x 340 mm (860 mm)		650 x 495 mm (1250 mm)	
Working distance	z	550 ±75 mm		760 ±100 mm		1100 ±150 mm	
Resolution	x,y	250 μm		300 μm		500 μm	
	z <sup>1</sup>	8.5 μm		12.7 μm		24 μm	
Repeatability	z(σ) <sup>1</sup>	< 3.0 μm		< 4.5 μm		< 8.5 μm	
Acquisition time <sup>2,3</sup>		0.5 ... 1 s					
Light source		LED					
Supply voltage		18 VDC ±33 %					
Current consumption		6 ... 12.5 A					
Connection		8-pin M12 socket for Gigabit Ethernet camera 1, connection to controller, 8-pin M12 socket for Gigabit Ethernet camera 2, connection to controller, 4-pin LEMO push-pull plug for sensor control (USB), connection to controller, 2-pin LEMO push-pull plug for supply voltage					
Installation		Mounting via flange adapter (see accessories)					
Temperature range <sup>4</sup>	Storage	-10 ... +50 °C (+14 ... +122 °F), non-condensing					
	Operation	+5 ... +40 °C (+41 ... +104 °F)					
Protection class (DIN EN 60529)		IP40					
Material		Carbon, aluminum, plastics					
Weight		7.0 kg (without controller)					
Control and display elements		2 LEDs on each camera (for device status, power, data transmission)					
Sensor SDK		Micro-Epsilon 3D Sensor-SDK					
3D evaluation software		Micro-Epsilon 3DInspect					
Functional extension		-	3DInspect Automation	-	3DInspect Automation	-	3DInspect Automation
Surface analysis software (optional)		surfaceCONTROL DefMap3D					

1) Measured on measuring object with cooperative surface in the mid of the measurement area while the “EnhancedSNR” parameter is enabled and a 3x3 mean value filter is used once at a consistent room temperature.

2) Duration that the sensor requires for the image acquisition of the pattern projections (without processing and evaluation time).

3) Applies for exposure times < 25 ms

4) Projector with active cooling. Air-cooled. Projection area and cooling area are separated.

SC2500 controller		
RAM		16 GB
Supply voltage		9 ... 36 V DC
Current consumption		3 ... 12.4 A
Digital interfaces		4 x Gigabit Ethernet (GigE Vision / GenICam) / USB 2.0 (sensor control) / PROFINET <sup>2</sup> / EtherCAT <sup>2</sup> / EtherNet/IP <sup>2</sup>
Connection		4-pin supply terminal strip, 4 x Ethernet
Installation		Mounting holes, DIN rail mounting kit
Temperature range	Storage	-40 ... 85 °C (-40 ... 185 °F)
	Operation <sup>1</sup>	-10 ... 60 °C (+14 ... +140 °F)
Shock (DIN EN 60068-2-27)		20 g / 11 ms half-sine
Vibration (DIN EN 60068-2-6)		3 g / 5 ... 500 Hz
Protection class		IP40
Material		Metal housing
Weight		2.8 kg
Control and indicator elements		2 LEDs for storage and power; 4 LEDs for COM1 TX/RX and COM2 TX/RX 1 power on/off switch

1) Max. permissible operating temperature with 0.7 m/s air blow

2) Connection via Processing Unit interface module

### 3.3 Control and Indicator Elements

Each of the two cameras has two LEDs for status indication on the rear side.

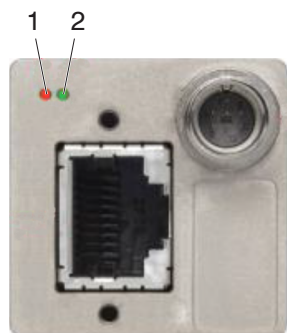

1	LED 1	Orange	Ethernet connection available
		Flashing orange	Ethernet data traffic
2	LED 2	Green	Power supply to the camera
		Flashing green	Boot process is running
		4 x fast flashing	Transmission error

Fig. 3 LED indicators of camera

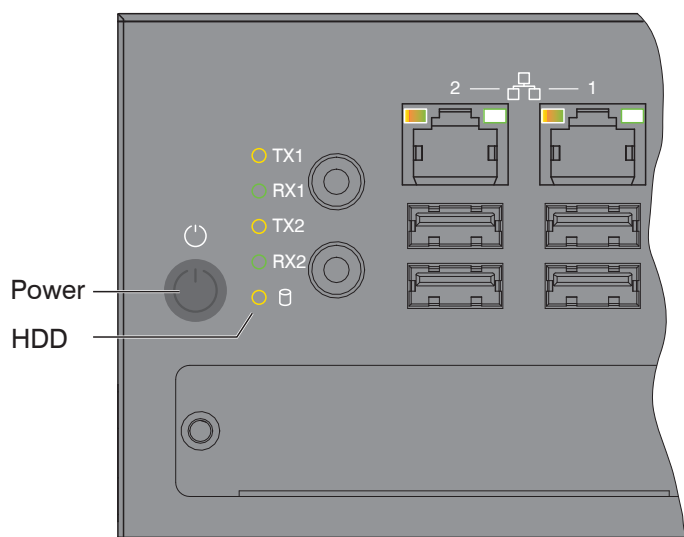

LED power	
Red	Off, supply voltage available
Green	Ready to use

LED HDD	Meaning
OFF	No access to hard drive
ON	Read and write access to hard drive

LED LAN 1 / 2	Meaning
Link LED (left):	
Constant orange	Gigabit Ethernet connection established
Constant green	100 Mbit Ethernet connection established
OFF	10 Mbit Ethernet connection established
Act LED (right):	
Green	Active data transmission
OFF	No data transmission

Power button	Turns on/off the controller
--------------	-----------------------------

Fig. 4 Controller LEDs, on/off switch

## 4. Delivery

### 4.1 Unpacking/Included in Delivery

- 1 Sensor surfaceCONTROL 3D 25x0
  - 1 Controller SC2500
  - 1 Cable harness/5 m/standard for surfaceCONTROL
  - 1 Assembly Instructions
  - 1 Calibration protocol
  - 1 Table power pack sensor
  - 1 Ethernet patch cable (Cat6A, grey, 5 m)
  - 1 DIN rail mounting kit for controller
  - 1 Power supply cable (4-pol. terminal block resp. open ends)
- ▶ Carefully remove the components of the measuring system from the packaging and ensure that the goods are forwarded in such a way that no damage can occur.
- ▶ Check the delivery for completeness and shipping damage immediately after unpacking.
- ▶ If there is damage or parts are missing, immediately contact the manufacturer or supplier.

### 4.2 Storage

Humidity: 20 % ... 80 % (non-condensing)

Temperature range (storage)

Sensor: -10 ... +50 °C

Controller: -40 ... +85 °C

## 5. Installation and Assembly

### 5.1 Sensor

All components of the sensor are preassembled at the factory.

▶ Refer to the dimensional drawings for the mounting dimensions.

**NOTICE**

Ensure careful handling during installation and operation.  
Damage to or destruction of the sensor

▶ Before connecting the sensor to the power supply and the system computer, mount it on a tripod or robot with the appropriate mounting adapters.

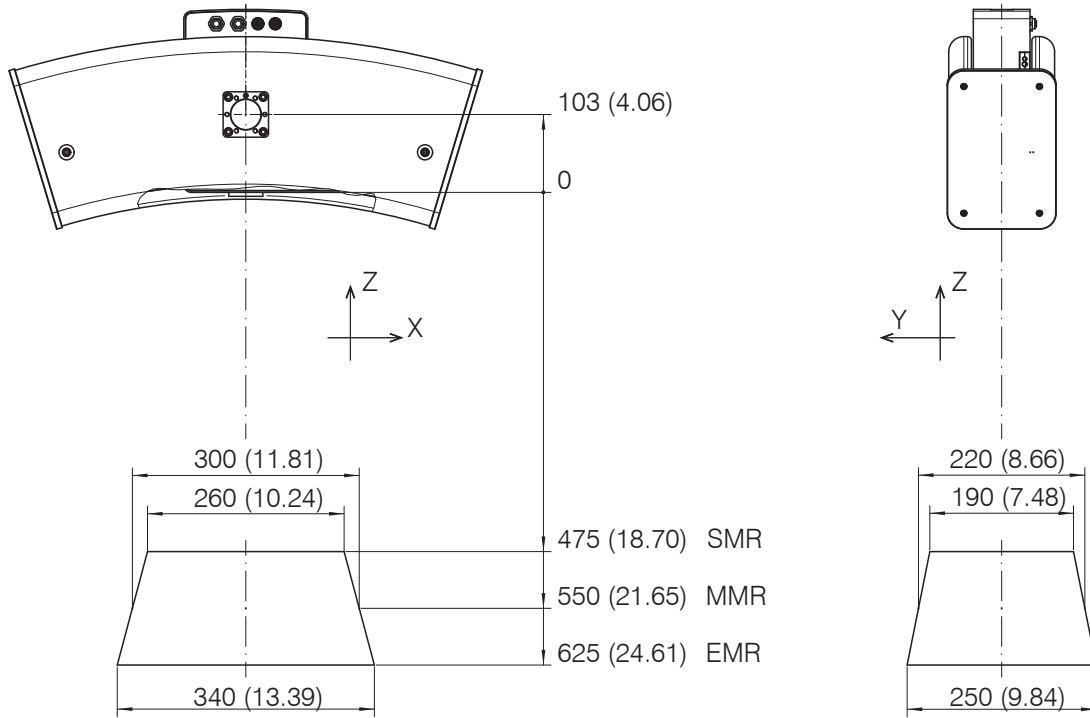

Fig. 5 Dimensional drawing of surfaceCONTROL 3D SC25x0-300 measurement area, dimensions in mm (inches)

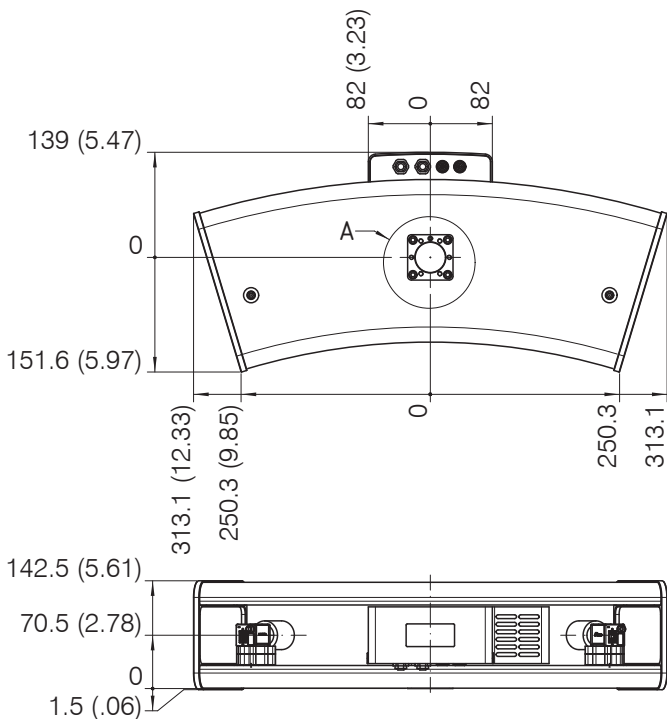

Fig. 6 Dimensional drawing of surfaceCONTROL 3D SC25x0 sensor, dimensions in mm (inches)

SMR = Start of measuring range      MMR = Midrange      EMR = End of measuring range

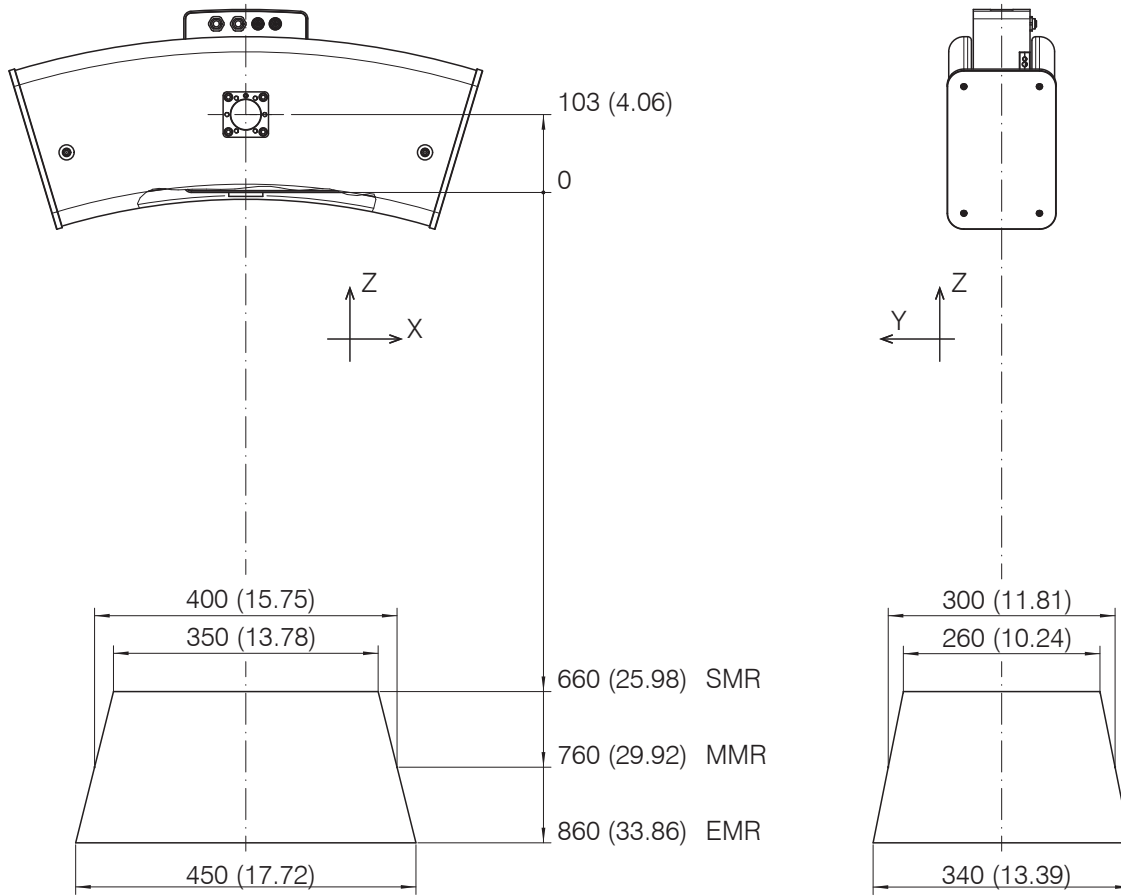

Fig. 7 Dimensional drawing of surfaceCONTROL 3D SC25x0-400 measurement area, dimensions in mm (inches)

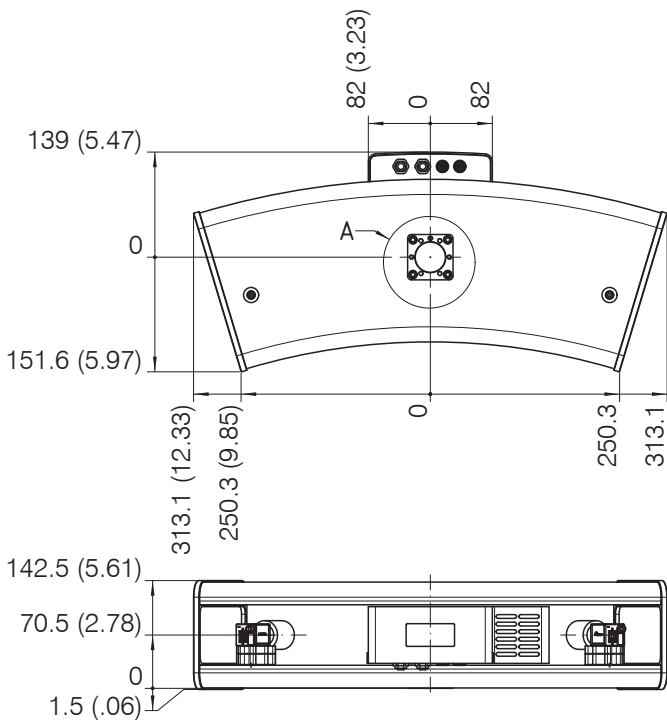

Fig. 8 Dimensional drawing of surfaceCONTROL 3D SC25x0 sensor, dimensions in mm (inches)

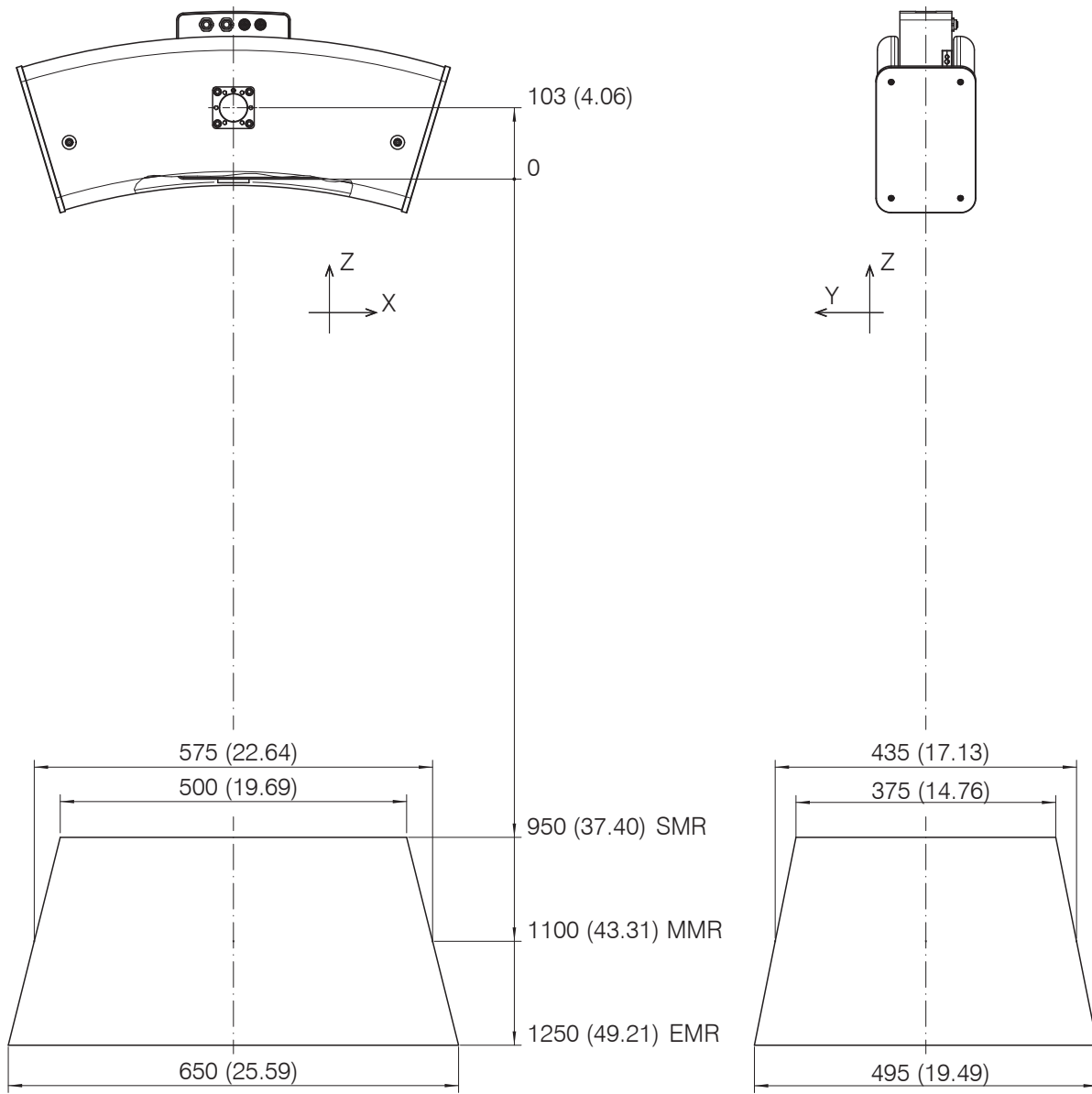

Fig. 9 Dimensional drawing of surfaceCONTROL 3D SC25x0-575 measurement area, dimensions in mm (inches)

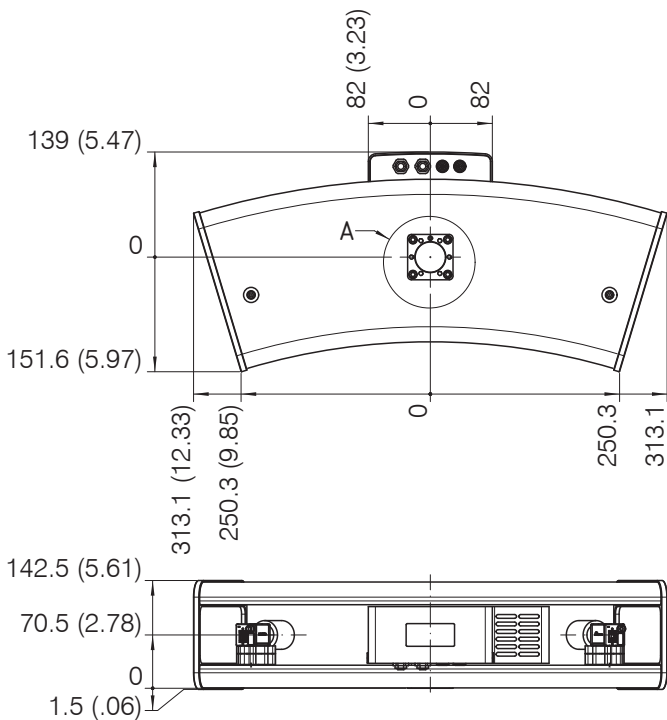

Fig. 10 Dimensional drawing of surfaceCONTROL 3D SC25x0 sensor, dimensions in mm (inches)  
 surfaceCONTROL 3D SC2500 / SC2510

## 5.2 Mounting Adapter

The sensor is attached either to a tripod, a robot or a portal.

For mounting the sensor on a tripod or a robot, corresponding mounting adapters (matt black anodized) are provided as separate accessories, see [Chap. A 2](#).

The sensors are optical sensors that operate in the  $\mu\text{m}$  range.

**NOTICE**

Ensure careful handling during installation and operation.  
Damage to or destruction of the sensor

The mounting adapters are always fastened to the sensor base with a total of 6 M6 screws. A metal pin on the underside of the sensor is used for unambiguous orientation of the adapter.

▶ Mount the sensor to the mounting adapter ensuring full contact over the entire surface.

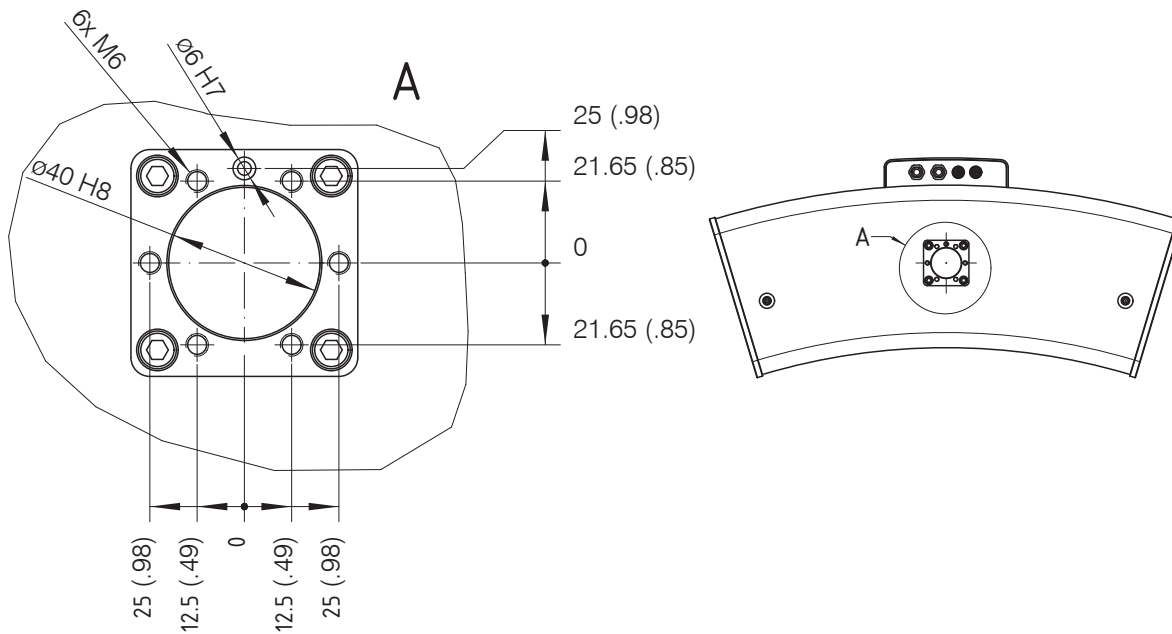

Fig. 11 Mounting dimensions of flange adapter, dimensions in mm (inches)

The sensor and mounting adapter must not be tilted to one another. All screws must be tightened. An improperly mounted adapter can cause the accurately reproducible positioning of the sensor to be impaired and the sensor, adapter and tripod connecting elements to be unevenly mechanically stressed.



### 5.3 SC2500 Controller

Mounting adapters enable wall mounting of the SC2500 controller; these are included in the scope of delivery.

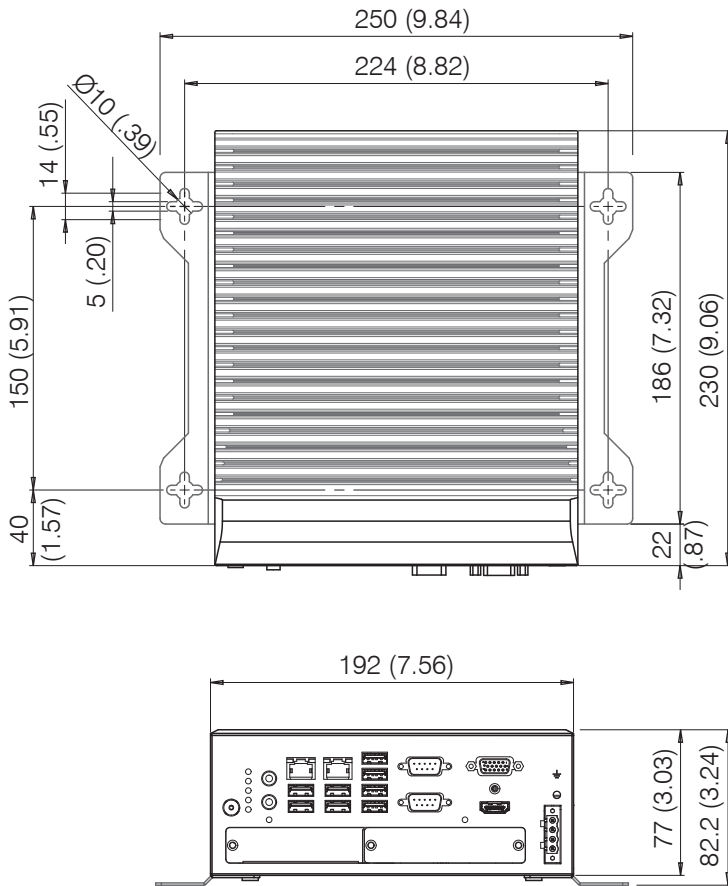

Fig. 12 Dimensional drawing of SC2500 controller with mounting adapter, dimensions in mm (inches)

➡ Remove the plastic covers from the preferred mounting surface of the controller.

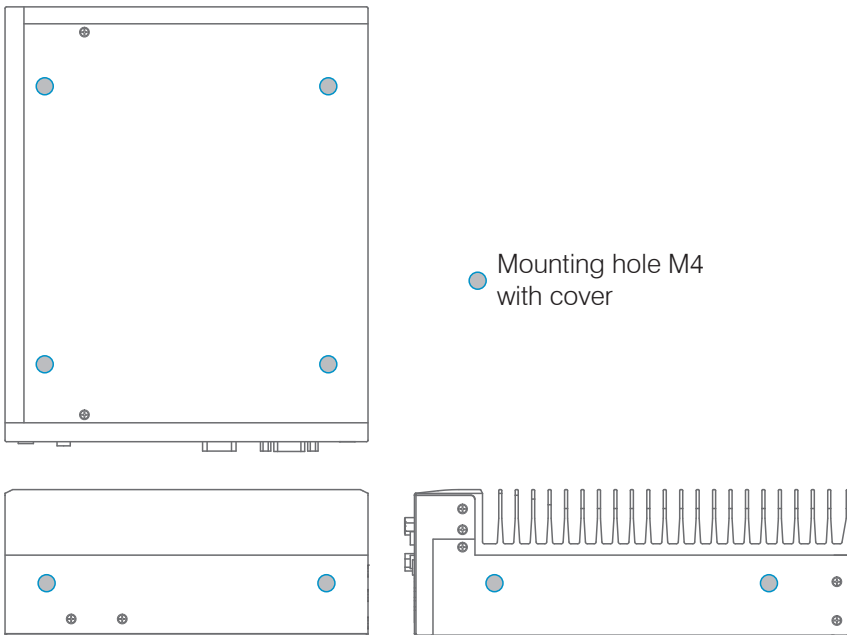
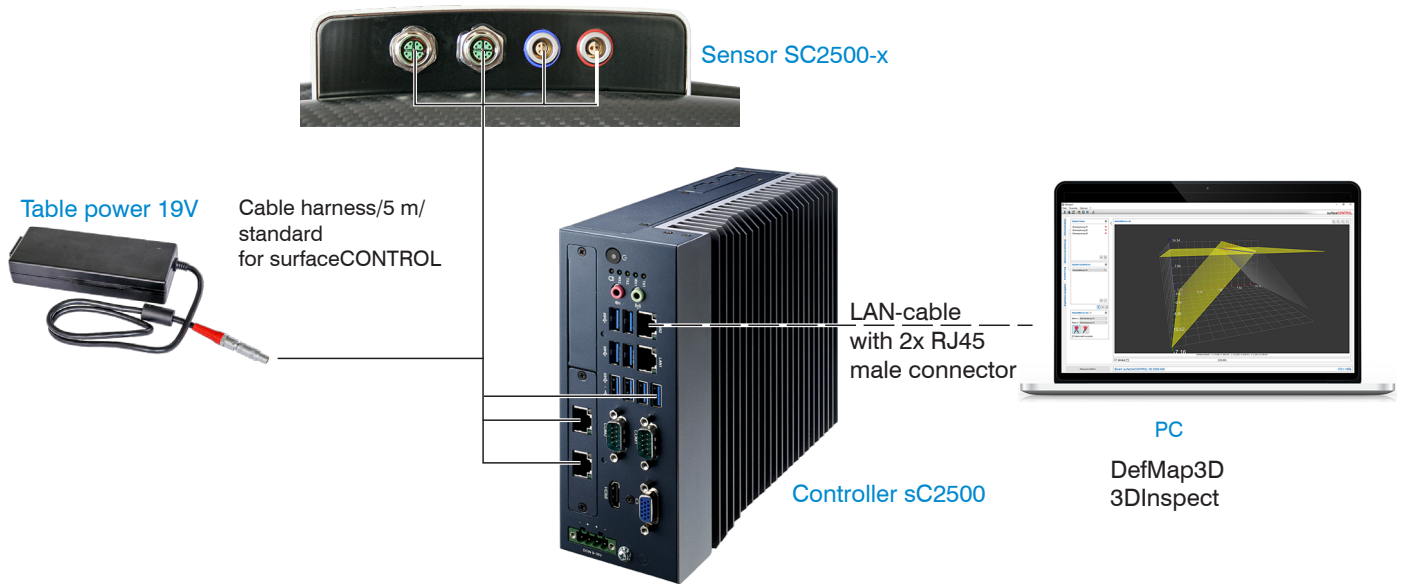

Fig. 13 Reference points for wall mounting

➡ Mount the controller.

## 5.4 Electrical Connections

### 5.4.1 Connection Diagram



### 5.4.2 surfaceCONTROL 3D 2500 Sensor

#### 5.4.2.1 General

All connectors of the sensor are located in the connector panel on the rear side.

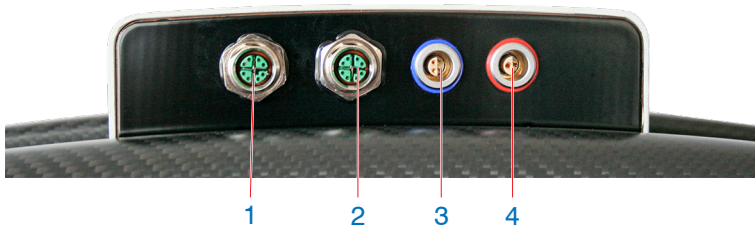

Fig. 14 Rear view of sensor with connectors

1	Ethernet port Camera 1
2	Ethernet port Camera 2
3	Sensor control
4	Power supply

#### 5.4.2.2 Supply Voltage (Power)

Pin	Signal	Comment	
1	V <sub>+</sub>	18 VDC ±33 % max. current consumption 12.5 A	
2	GND	0 V	

Fig. 15 Pin assignment connector power port

The cable shield is connected to the connector housing.

A 2-pin LEMO PushPull connector is used on sensor side.

**i** Only use the included table power pack for the power supply of the surfaceCONTROL 2500 sensor.

### 5.4.2.3 Sensor Control (USB)

Pin	Signal
1	USB D+
2	USB D-
3	USB VCC
4	GND



Fig. 16 Pin assignment connector USB port

The cable shield is connected to the connector housing.

The sensor is configured and controlled via the available USB 2.0 interface. Use only the supplied USB cable.

A 4-pin LEMO PushPull connector is used on sensor side.

The USB-A connector on controller side can be connected to a USB 2.0 or USB 3.0 port.

### 5.4.2.4 Image Data Transmission (Gigabit Ethernet)

Pin	Signal
1	Data1 +
2	Data1-
3	Data2+
4	Data3+
5	Data3-
6	Data2-
7	Data4+
8	Data4-

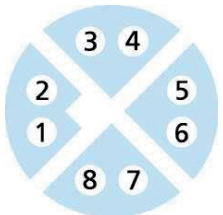

Fig. 17 Pin assignment connector "Ethernet port"

For the image data output of the cameras via Gigabit Ethernet, the sensor has two Gigabit Ethernet interfaces. The sensor supports only the transmission with 1 Gbit.

8-pin, X-coded, M12 round connectors with screwed connections are used on sensor side.

The connection and tightening of the Ethernet cable to the sensor can be done by hand and does not require any tools. Proceed as follows for this:

- ▶ Carefully insert the cable connector into the port on the sensor.
- ▶ Turn the cable connector until you feel the latching of the inner groove into the corresponding guide of the port.

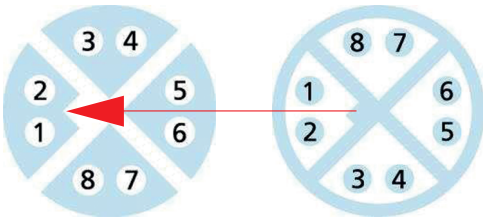

Fig. 18 Connecting Ethernet connector to port

- ▶ Tighten the cable connector.

RJ45 connectors are used on the PC side.

**i** Use only the Ethernet cable supplied in the scope of delivery.

### 5.4.3 surfaceCONTROL 3D 2500 Controller

#### 5.4.3.1 General

All connections for the controller are located on the front.

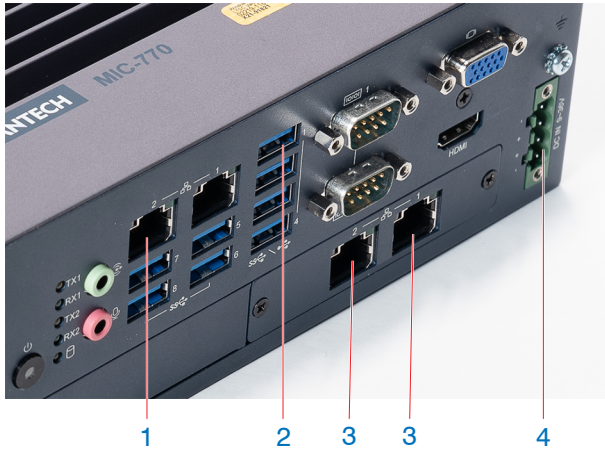

Fig. 19 Rear view of sensor with connectors

1	Ethernet port, PC connection
2	Sensor control
3	Ethernet port Camera 1 and 2
4	Power supply

#### 5.4.3.2 Supply Voltage (Power)

The power supply connection is a 4-pin plug connector.

Pin/Designation	Comment
+	9 V ... 36 V DC (nominal value 24 V, max. power consumption 112 W)
-	0 V

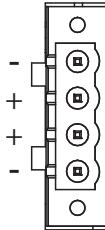

Fig. 20 Pin assignment of the power supply connection, view: plug on housing side

The operating voltage is protected against polarity reversal. Use only shielded lines or original cables from the accessories program for the power supply connection or the outputs.

#### 5.4.4 Gigabit Ethernet Connection

The Ethernet connection is the standard connection to the PC. The sensor supports transmission at 1 Gbit/s. Four 8-pin RJ45 sockets are installed in the housing.

We recommend you use the optional Cat6A category patch cables with cable lengths of 2 m, 5 m or 10 m for the Ethernet connection.

Due to the high data rate, we recommend a high-quality Ethernet PC plug-in card, for example, Intel-Pro/1000 PT. Preferably the sensors should be connected directly to the network connection or using a high-quality switch. A hub would cause massive data collisions and may not be used. On the PC, one or more network cards should always be intended solely for the sensors.

Operating the sensors via Ethernet requires no additional driver installation. However, the network settings must be specified correctly:

- The sensor supports DHCP. This setting is enabled by default and has priority over searching in the link local network.
- A fixed IP address can be assigned.
- Various network settings (e.g. firewall or packet filters) can interfere with communications with the sensor.
- The sensor supports jumbo frames up to 9014 bytes/packet; however, in that case all network components must also support jumbo frames up to that size.

#### 5.5 Installation Instructions

For all connection cables, use only the appropriate cables from the optional accessories.

**NOTICE**

Tighten the cable connectors. The recommended tightening/screwing torque is at most 1.0 Nm.

Do not apply force when tightening.

> Damage to or destruction of the sensor

Lay all connection cables in accordance with the generally applicable measuring technology regulations, i.e. for example not directly next to pulse-carrying lines, preferably in a separate cable duct.

The minimum bending radii are three times the cable diameter and must not be less than this.

## 5.6 Initial Operation

---

**NOTICE**

The sensor and the controller may only be connected to peripherals when they do not carry power, that is, only when the supply voltage has been switched off.

---

- ▶ Mount the sensor according to the assembly instructions, see [Chap. 5.1](#).
- ▶ Mount the controller as per the assembly instructions, see [Chap. 5.3](#).
- ▶ Connect the sensor and the controller to the cable harness included in the delivery, see [Chap. 5.4.1](#).
- ▶ Connect the controller to the PC. To do so, use a common Ethernet cable of category CAT5e or higher.
- ▶ Connect the sensor to the power supply, see [Chap. 5.4.2.2](#).
- ▶ Connect the controller to the power supply, see [Chap. 5.4.3.2](#).

## 6. Operation

### 6.1 Turning On

Switch on the power supply (24 VDC) on the controller.

➤ Press the **Power** button on the controller.

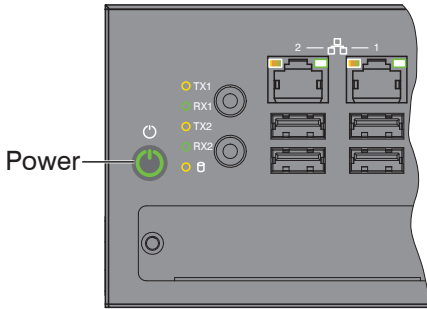

The **Power** LED on the controller is illuminated red if the power supply is sufficient, and green after pressing the **Power** button.

It starts when the supply voltage is applied.

**i** The surfaceCONTROL 3D 25x0 sensor requires a warm-up time of typically 60 minutes for precise measurements.

### 6.2 Operating Programs

Various programs are provided for operation of the sensor.

- 3DInspect solves industrial 3D measurement tasks.
- You can use surfaceCONTROL DefMap3D for the analysis of individual surfaces with surfaceCONTROL 3D 25x0.

### 6.3 Installation

#### 6.3.1 Requirements

The following minimum system specifications are necessary for the use of the operating programs:

- Windows 10 (64 bit)
- $\geq 2$  GHz processor (64 Bit) or higher
- 4 GB RAM
- Screen resolution: 1280 x 1024
- Graphics card/GPU with OpenGL 3.1 or higher

The following procedure is necessary in order to install the software:

1. Install the hardware of the Ethernet interface(s) if not present.
2. Install the software.
3. With DefMap3D: use the USB dongle required for this.
4. Connect the controller of the surfaceCONTROL 3D 25x0 measuring system to the PC via Ethernet. Do not use hubs, see [Chap. 6.3.2](#).

**i** If your network card supports the VLAN option, this option must be disabled.

### 6.3.2 Connecting surfaceCONTROL 3D 25x0 to the PC

To connect surfaceCONTROL 3D 25x0 via Ethernet to the PC, proceed as follows:

1. Complete the installation of the software.
2. Connect surfaceCONTROL 3D 25x0 to the PC using the Ethernet interface.
3. Turn on the power supply.
3. Wait until the surfaceCONTROL 3D 25x0 measuring system is recognized by the PC. This takes about 1 minute.

**I** To be able to operate the measuring system, the controller and the PC must be located in the same subnet.

The sensor starts in DHCP mode. If there is no DHCP server in the network or if no address has been assigned manually, the sensor and network adapter assign themselves an address (Link Local Address).

You can now operate the surfaceCONTROL 3D 25x0 measuring system using the operating programs listed above.

## 6.4 Notes for Operation

### 6.4.1 Measurement Area

The measurement area of the sensors is factory-set.

The area illuminated by the projector is relevant for the actual measurement area of the sensor. The cameras are arranged in such a way that both cameras capture the area illuminated by the projector within the complete measuring volume.

The measuring range in Z direction is trapezoidal due to the point-shaped light source of the projector and the fan-out over the lens.

### 6.4.2 Calibration

The calibration of the sensor serves to determine the orientation of the camera coordinates in the coordinate system of the inspection system and is carried out with the aid of a pre-calibrated calibration target.

The sensor is factory calibrated upon delivery. An acceptance report is included with each sensor.



### 6.4.3 Positioning of Sensor and Test Object

#### 6.4.3.1 General

- Note the following instructions for optimum positioning of the sensor and test object.
  - Observe an optimum distance between the sensor and the surface of the test object, see [Chap. 3.2](#).
  - Align the sensor with predominantly diffusely reflecting surfaces almost perpendicular to the surface. To avoid direct reflection, we recommend that you tilt the sensor by a few degrees.
  - In the case of partially glossy surfaces, reflections from the test object can be reduced by inclining the sensor by up to 30° with respect to the surface of the test object.

#### 6.4.3.2 Alignment with Crosshair

You will achieve the best results in the mid of the measurement area (focal range of cameras)

- ▶ In the main view, switch from the 3D View to the Image data.
- ▶ Switch to the Data acquisition tab.
- ▶ Select Sensor settings > Pattern projection > Positioning.

The positioning pattern is displayed in the image data.

- ▶ Use the positioning pattern to easily and optimally align the sensor in the mid of the measurement area. Align the pattern of the projection with the superimposed pattern.

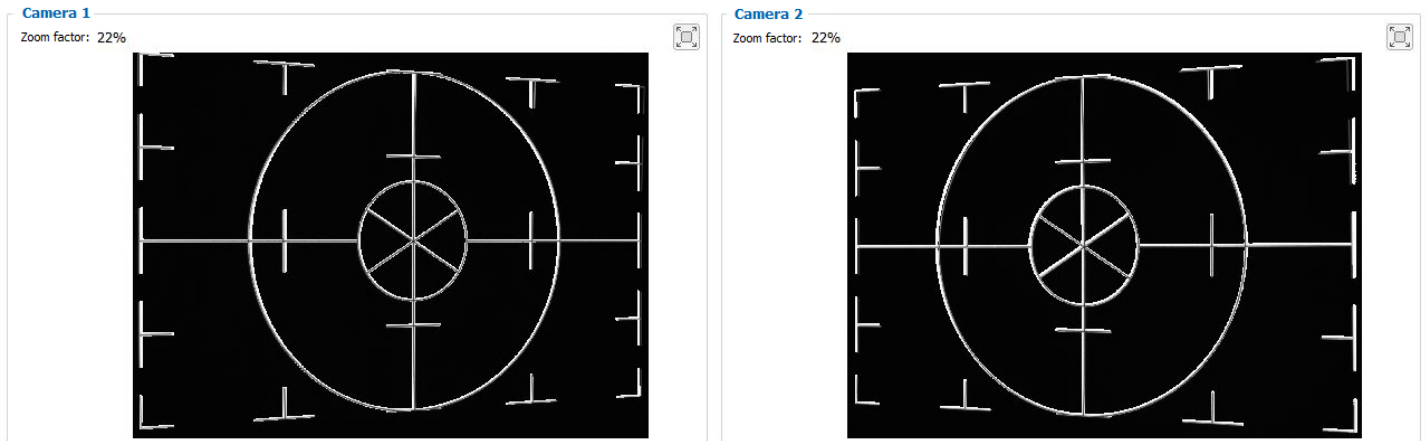

Fig. 21 Result of camera images when aligned with crosshair

Examples:

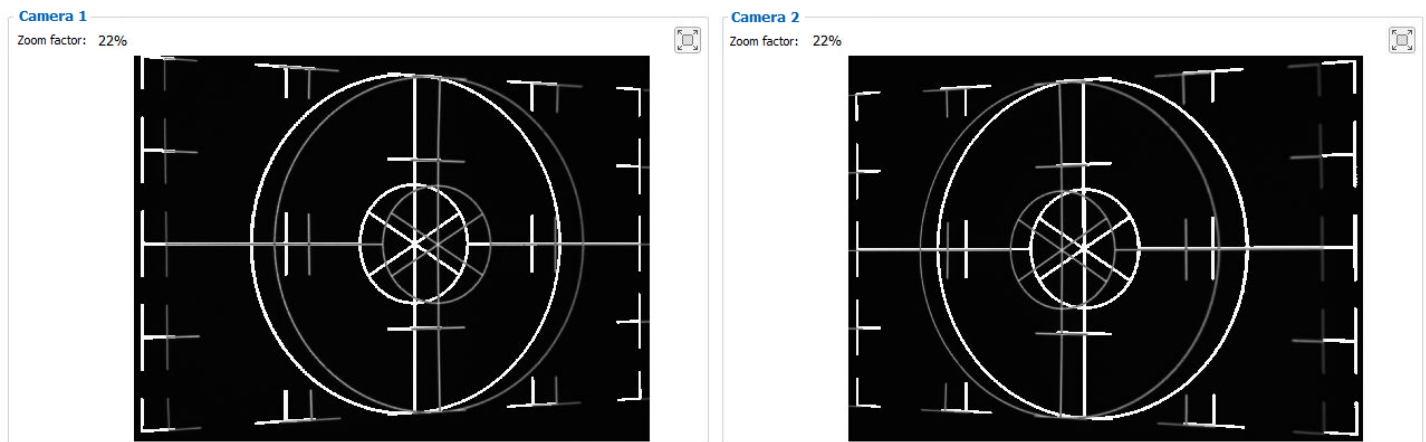

Fig. 22 Distance too short

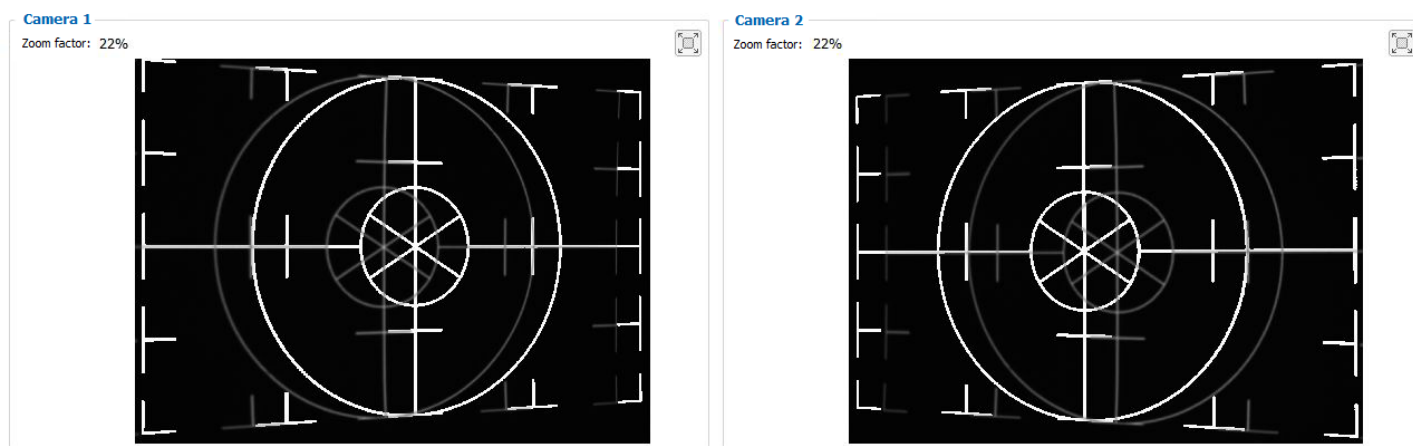

Fig. 23 Distance too large

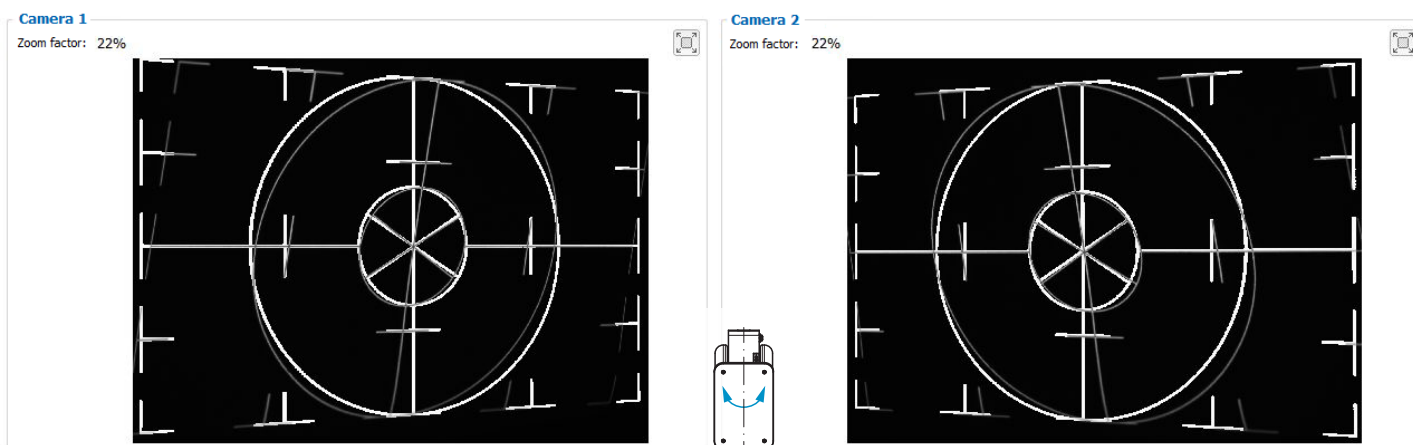

Fig. 24 Lateral tilt, tilted around the x-axis, distance correct

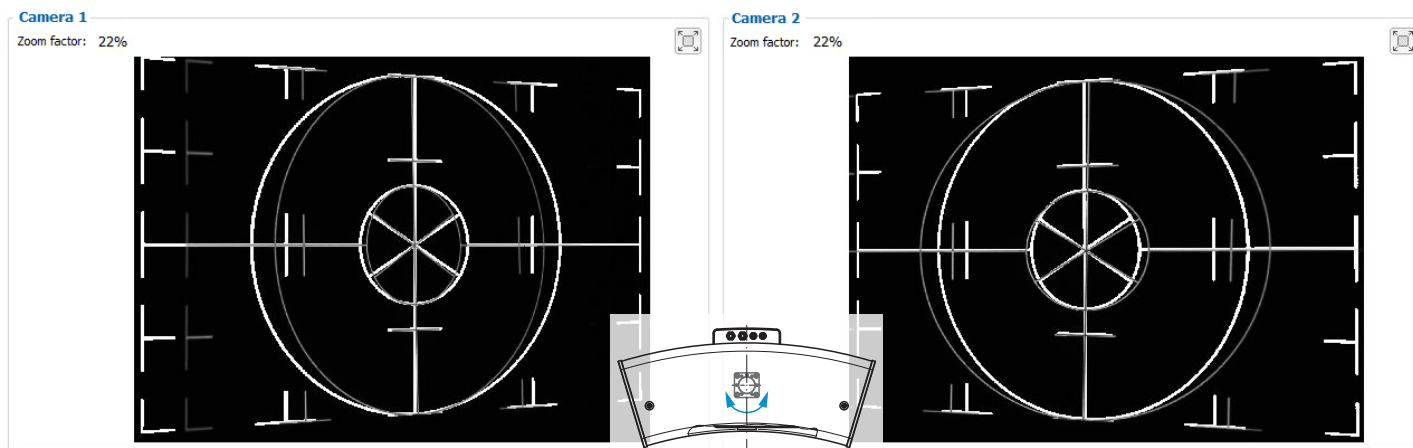

Fig. 25 Lateral tilt, tilted around the y-axis, distance correct

The screens shown were created with the 3DInspect software from Micro-Epsilon.

Further details can be found in the respective operating instructions of the software provided by Micro-Epsilon or in the GenICam parameter description, see [Chap. A 3](#).

### 6.4.4 Exposure

The projected fringe pattern should be well recognizable over the entire measurement plane (not too light/dark) in order to avoid overdriven and underdriven pixels.

The `Exposure` time parameter enables you to adjust the exposure.

- ▶ In the main view, switch from the 3D View to the Image data.
- ▶ Switch to the Data acquisition tab.
- ▶ Select `Sensor settings > Pattern projection > Pattern`.
- ▶ Select a suitable exposure time in `Sensor settings > Exposure`.

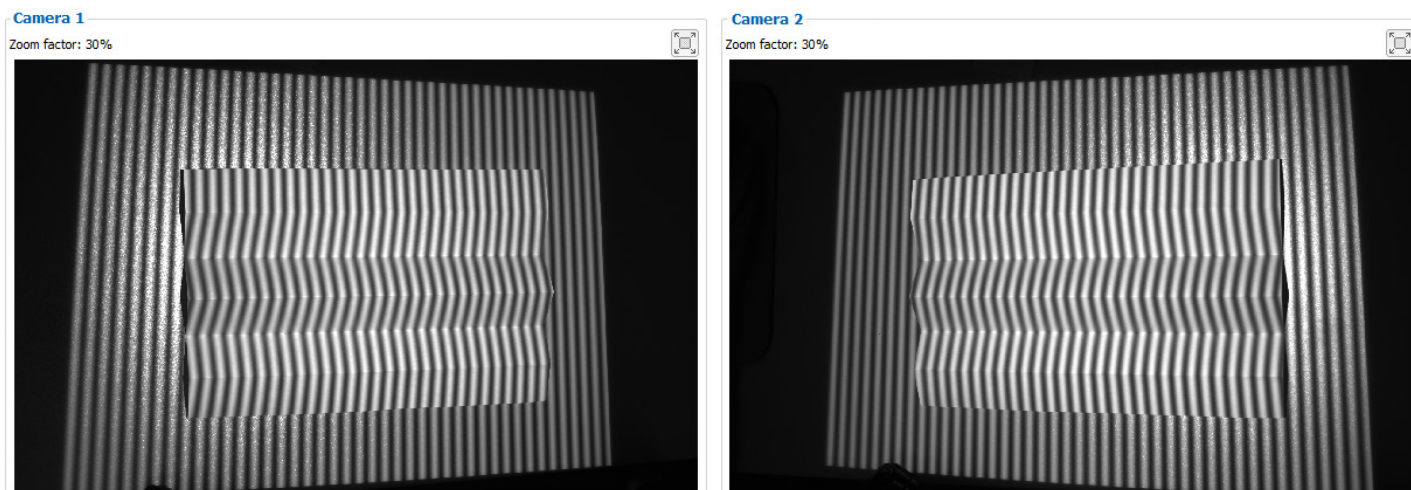

Fig. 26 Result of camera images with good exposure

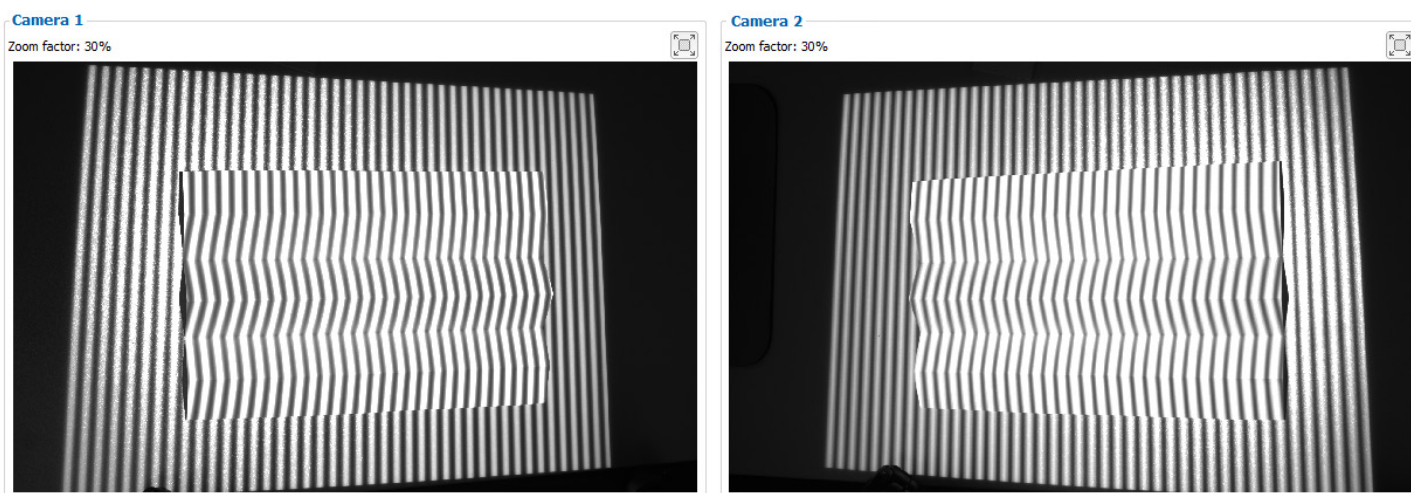

Fig. 27 Camera image, measuring object overexposed

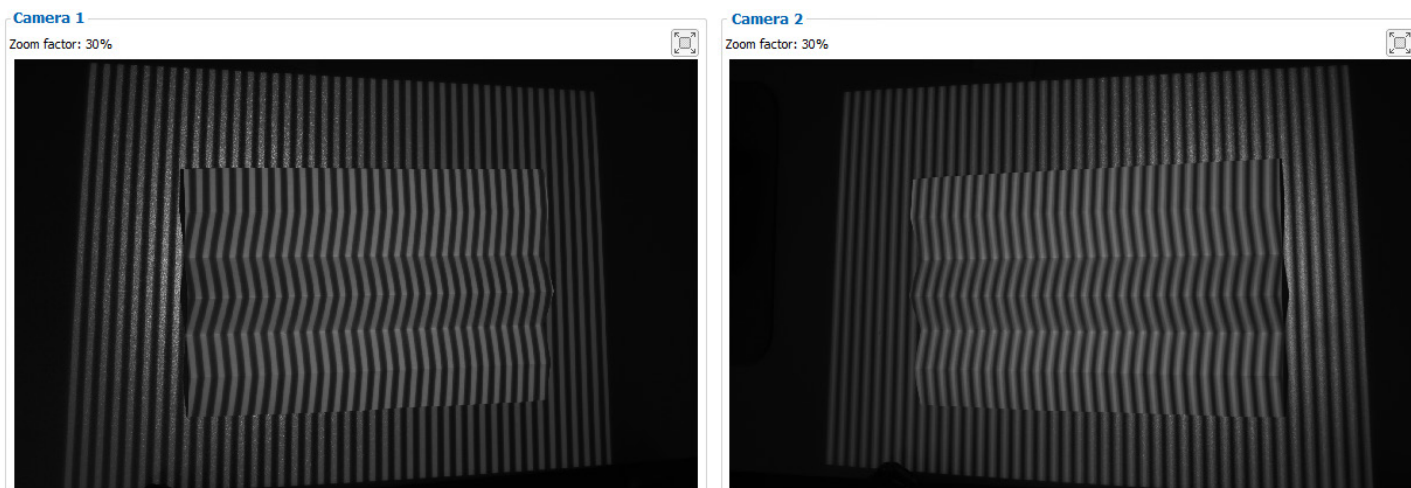

Fig. 28 Camera image, measuring object underexposed

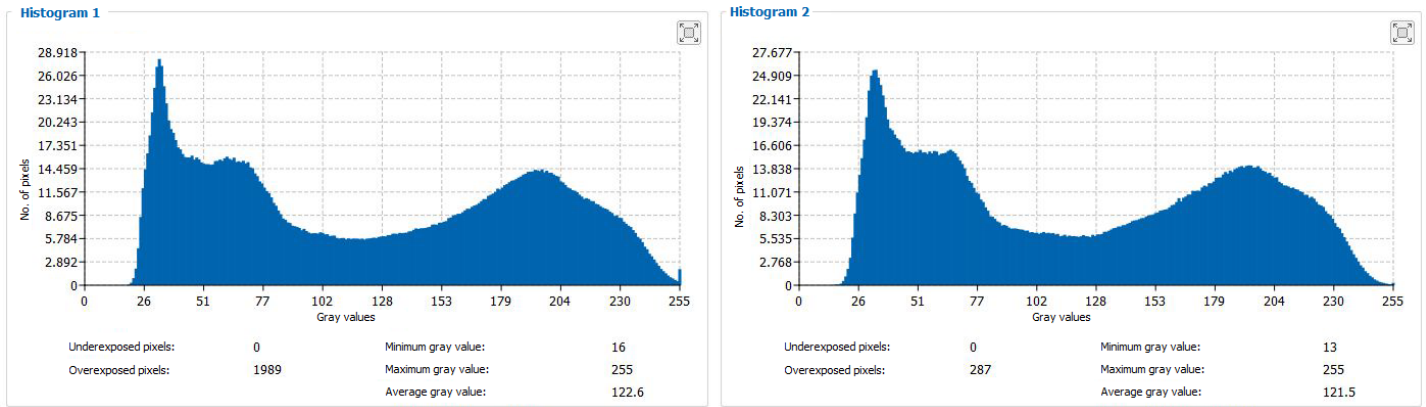

Fig. 29 Example of an optimally selected exposure time

The distribution of gray values in the histogram should be approximately uniform with the projected pattern. The number of overexposed and underexposed pixels should be reduced to a minimum.

The screens shown were created with the 3DInspect software from Micro-Epsilon.

## 6.5 Interferences

### 6.5.1 Reflection Factor of the Surface of the Target

The sensor evaluates the diffuse portion of the reflected light. Any statement about a minimum reflection factor is only possible with reservations. A preliminary examination is necessary for using the sensor on reflective or highly reflective objects.

### 6.5.2 Color Differences

Color differences between test objects result in apparent changes of the surface texture of the test object and thus also influence the calculation of the 3D data from the acquired images. Therefore color differences can result in increased measurement inaccuracies and reduced detection performance.

As the exposure parameters can only be changed as a whole, careful matching of the exposure to the target surface is recommended.

### 6.5.3 Temperature Influences

When the sensor is commissioned a warm-up time of at least 30 minutes is required to achieve uniform temperature distribution in the sensor. Large temperature fluctuations and changes of the ambient climate act directly on the sensor and its fixing elements and can thus change the detection performance.

- It is recommended to operate the sensor under as constant as possible ambient conditions. A new calibration is required if the ambient conditions change permanently.

### 6.5.4 Ambient Light

For external light suppression, the sensor is equipped with corresponding filters in front of the camera lenses. They allow only a narrow (band-limited) wavelength range around the wavelength of the light projected onto the test object. In general, additional shielding of external light directly emitted on the target or reflected in the sensor is advisable.

- Pay particular attention to unwanted reflections of the projected structured light outside the target area (background, object holder or similar) which can be reflected back again into the view area of the sensor.
- Matt black surface coatings are recommended for all objects outside the measurement area (object holders, transport equipment, grippers or similar).

### 6.5.5 Mechanical Vibrations

As high resolutions in the  $\mu\text{m}$  range will be achieved with the inspection system, particular attention must be paid to as vibration-free a set-up of sensor and test object as possible.

### 6.5.6 Surface Roughness and Texture

Surface roughnesses of the order of  $5\ \mu\text{m}$  and more as well as textures on the surface result in increased “surface noise”. In addition, direct reflections of the projected light can also occur on grinding marks or small scratches on the surface. This can result in inaccurate measured values. Remedy can possibly be provided by adjusting the exposure or by other sensor settings, e.g. filter.

### 6.5.7 Shadowing Effects and Multiple Reflections

Shadowing effects and multiple reflections occur particularly frequently on strongly curved surfaces. Steep edges and large differences in height lead to certain areas on the test object being underprojected. Furthermore, parts of the test object cannot be detected completely by the cameras, which leads to a loss of measuring points on the surface. This effect can be diminished by a change in orientation of the sensor to the surface.

Multiple reflections of the projected pattern from certain areas of the surface to other areas of the surface lead to overlaps of the original pattern. This can result in inaccurate measured values. Remedy can possibly be provided by selectively masking the projected pattern and not illuminating the undesirably reflecting areas. The procedure for masking certain areas is described in the instruction manual of the surfaceCONTROL Defmap3D software. However, if you want to check these areas anyway, repeated data acquisition with modified masking is necessary.

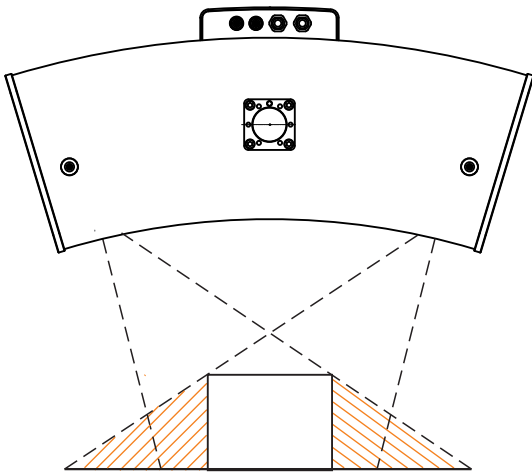

Fig. 30 Receiver shadowing

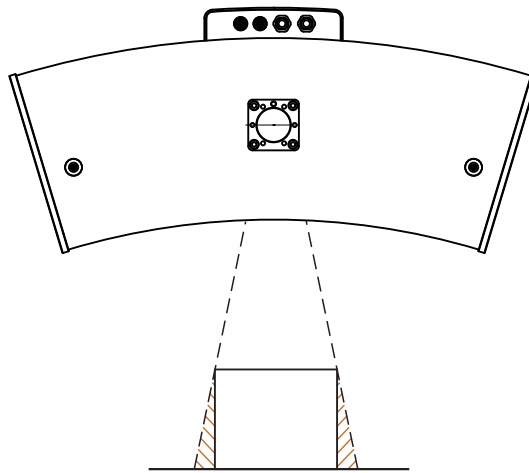

Fig. 31 Projection shadowing

## 6.6 Cleaning

### 6.6.1 Housing

It is not recommended to clean the housing. But if cleaning needs to be carried out, this can be done using water without additives and a soft cloth.

### 6.6.2 Protective glasses / Filter

The lenses of the cameras and the projector are protected as standard by protective glass filters screwed onto the lenses. We recommend cleaning the protective filters regularly.

#### Dry Cleaning

You can use an anti-static brush for lenses, or blow down the covers using dehumidified, clean, oil-free compressed air.

#### Wet Cleaning

Use a clean, soft, lint-free cloth or lens cleaning paper and pure alcohol (isopropyl alcohol) to clean the protective glass pane.

Never use commercially available glass cleaner or other cleaning agents.

#### NOTICE

When cleaning the protective filters, make sure that you do not change the settings of the lenses and do not exert any strong pressure on the cameras or the lenses.

> Recalibration is possibly required

## 7. Disclaimer

All components of the device have been checked and tested for functionality in the factory. However, should any defects occur despite careful quality control, these shall be reported immediately to MICRO-EPSILON or to your distributor / retailer.

MICRO-EPSILON undertakes no liability whatsoever for damage, loss or costs caused by or related in any way to the product, in particular consequential damage, e.g., due to

- non-observance of these instructions/this manual,
- improper use or improper handling (in particular due to improper installation, commissioning, operation and maintenance) of the product,
- repairs or modifications by third parties,
- the use of force or other handling by unqualified persons.

This limitation of liability also applies to defects resulting from normal wear and tear (e.g., to wearing parts) and in the event of non-compliance with the specified maintenance intervals (if applicable).

MICRO-EPSILON is exclusively responsible for repairs. It is not permitted to make unauthorized structural and / or technical modifications or alterations to the product. In the interest of further development, MICRO-EPSILON reserves the right to modify the design.

In addition, the General Terms of Business of MICRO-EPSILON shall apply, which can be accessed under Legal details | Micro-Epsilon <https://www.micro-epsilon.com/impresum/>.

For translations into other languages, the German version shall prevail.

## 8. Service, Repair

If the sensor, controller or cable harness is defective:

- If possible, save the current sensor settings in a parameter set to reload them into the sensor after the repair.
- Please send us the affected parts for repair or exchange.

If the cause of a fault cannot be clearly identified, please send the entire measuring system to:

INB Vision AG  
Brenneckestraße 20, ZENIT II  
39118 Magdeburg / Germany

Tel. +49 (0) 391 / 6117-300  
Fax +49 (0) 391 / 6117-301

[info@inb-vision.com](mailto:info@inb-vision.com)  
[www.inb-vision.com](http://www.inb-vision.com)

## 9. Decommissioning, Disposal

➡ Remove the connection cables from the sensor and the controller.

Incorrect disposal may cause harm to the environment.

➡ Dispose of the device, its components and accessories, as well as the packaging materials in compliance with the applicable country-specific waste treatment and disposal regulations of the region of use.



## Appendix

### A 1 Accessories

Cable harness/5 m/standard for surfaceCONTROL		Cable harness for connecting a sensor to the controller, contains the cables for data transmission of both cameras and sensor control; length 5 m, total cable diameter: approx. 6.8 mm, minimum bending radius with continuous movement: 10x cable diameter.
---	---	--

### A 2 Optional Accessories

Table power pack		Table power pack for sensor supply, input 100-240 VAC 50/60 Hz ~1.8 A, Output 19 VDC/7.89 A
X95/dovetail mounting adapter		Adapter for mounting on X95 profile (Qioptiq) or on tripod head with dovetail
47° dovetail mounting adapter		Adapter for mounting on tripod head with dovetail
Transport case		FlightCase for transporting sensors and accessories
Calibration target		Calibration target for calibrating the sensor
2D/3D Gateway		Fieldbus coupler for 2D/3D sensors combined with 3DInspect, configurable for PROFINET, EtherNet/IP and EtherCAT, Evaluations from 3DInspect can be transmitted to a PLC via one of these fieldbus systems, Sensor settings can be loaded by a controller via 3DInspect using parameter set mapping,

<p>Tripod set</p>		<p>Tripod for mounting and alignment of surfaceCONTROL 3D sensors, including tripod bag, ground spreader, tripod head, tripod adapter</p>
<p>Column stand</p>		<p>Column stand for mounting and alignment of surfaceCONTROL 3D sensors</p>



## A 2.1 Drawings of Mounting Adapter

### A 2.1.1 X95/Dovetail Mounting Adapter

The X95/dovetail mounting adapter is used to mount the sensor on a quick release plate with a dovetail profile of size 050/87 or to the profile system X95 of the manufacturer Linos (Qioptiq).

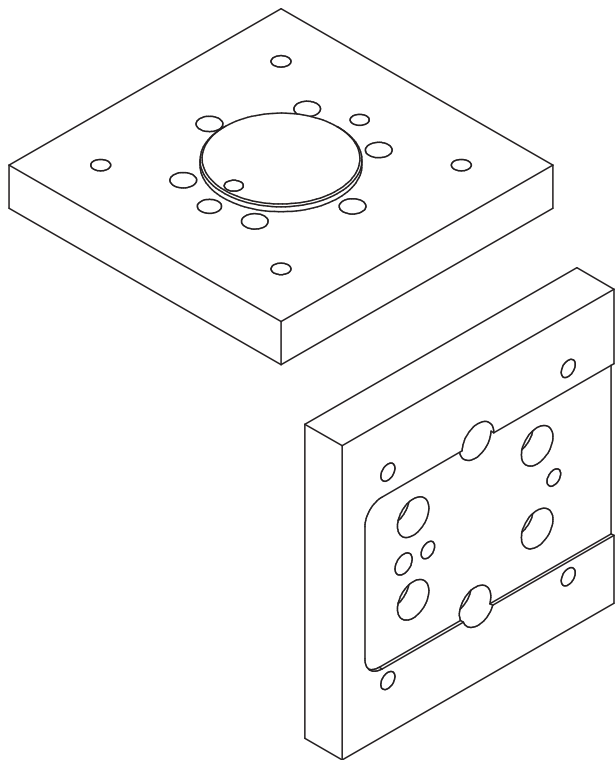

Fig. 32 View of X95/dovetail mounting adapter

The outer dimensions of the adapter are 95 mm x 95 mm x 15 mm.

### A 2.1.2 47° Dovetail Mounting Adapter

The 47° dovetail mounting adapter is used to mount the sensor on a quick release plate with a dovetail profile of size 050/87. The adapter is an adjustment for the operation of the sensor with a 43° 2-way ball tilt head. The adapter angle of 47° allows to directly align the sensor perpendicular to the ground.

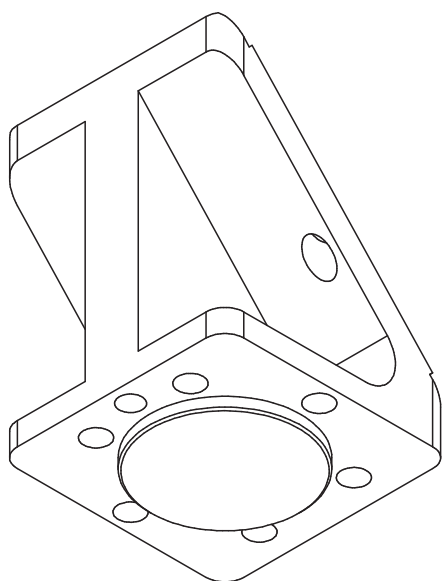

Fig. 33 View of 47° dovetail mounting adapter from below (sensor side)

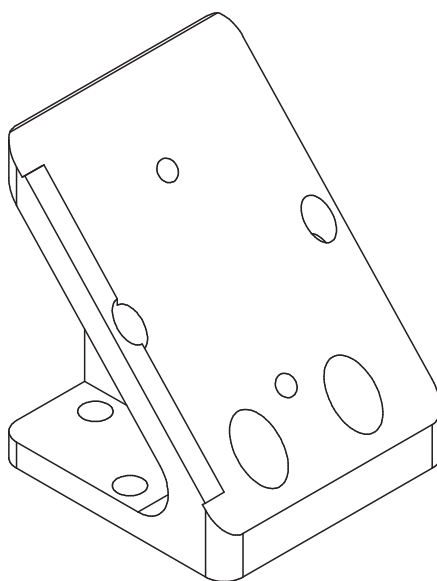

Fig. 34 View of 47° dovetail mounting adapter from above (tripod side)

The outer dimensions of the adapter are 60 mm x 60 mm x 76.6 mm.

### A 3 GenICam surfaceCONTROL Parameters

Details about setting the parameters are available in the software description, see 3D-View operating instructions.

#### Parameter Description

Observe the notes below if you operate the sensor with a third party library for GenICam/GigE Vision:

- The library must support GigE Vision 2.1. In particular, `MultiPart` mode must be supported.
- Three sources are available to set the parameters of the sensor, see the `SourceSelector` description below. However, data are always transmitted using `StreamChannel 0`. Before starting data transmission with the `AcquisitionStart` command, the entry `Source0` must be selected as `SourceSelector`.
- The network card used should be configured as follows:
  - Jumbo frames: enable/use largest possible value
  - Interrupt moderation: enable
  - Interrupt moderation rate: adaptive
  - Receive buffer: use largest possible value
- The `Coord3D_C32f` pixel format is used for 3D measurements. If this pixel format is not supported by the library used, the `Mono16` pixel format can be used as an alternative. In that case, however, the resolution or measurement area is limited.
- The operating mode and sensor data transmitted are controlled using the parameter `ComponentEnable` and the associated selectors `SourceSelector`, `RegionSelector` and `ComponentSelector`, as well as via `TriggerMode` and `TriggerSoftware`. The following modes are possible, among others:
  - Setup operation (continuous transmission of raw images):
    - `TriggerMode = Off`
    - `ComponentEnable [Source1][Region0][Intensity] = 1`
    - `ComponentEnable [Source2][Region0][Intensity] = 1`
    - Set all other selector combinations for `ComponentEnable` to 0
    - `SourceSelector = Source0`
    - Command `AcquisitionStart`
  - Measuring operation 3D (triggered continuous 3D measurement):
    - `TriggerMode = On`
    - `TriggerSource = Software`
    - `ComponentEnable [Source0][Scan3dExtraction0][Range] = 1`
    - If you want a mask image for invalid points:  
`ComponentEnable [Source0][Scan3dExtraction0] [Confidence] = 1`
    - Set all other selector combinations for `ComponentEnable` to 0
    - `SourceSelector = Source0`
    - Command `AcquisitionStart`
    - Trigger any number of measurements by using command `TriggerSoftware`

The parameters marked `Locked` cannot be changed when data transmission is active.

Name	Description	Documentation Text
<b>Device Control</b>		
DeviceTemperatureSelector	Selects the location within the device, where the temperature will be measured.	Serves as a switch for the temperature sensor to be read: Internal - internal sensor temperature Cpu - processor temperature CpuBoard - temperature of processor's circuit board LED - LED temperature CameraSensorBoard1 - internal temperature of camera #1 CameraSensorBoard2 - internal temperature of camera #2
DeviceTemperature [DeviceTemperatureSelector]	Device temperature in degrees Celsius (C).	Temperature of the component selected in DeviceTemperatureSelector.
<b>Source Control</b>		
SourceSelector	Selects the source to control.	Serves as a switch for the data source to be configured: - Source0: Virtual source for 3D measured data - Source1: Camera 1 - Source2: Camera 2
<b>Image Format Control</b>		
RegionSelector	Selects the Region of interest to control.	Serves as a switch for the parameters to describe the measuring field. Note that this switch also depends on the SourceSelector. The following settings are possible: - Region0: Describes the measuring field of the cameras [Source1] or [Source2] - Scan3dExtraction0: Describes the 3D measuring field [Source0]
Width[SourceSelector] [RegionSelector]	Width of the image provided by the device (in pixels).	The number of pixels in u-direction in the camera image [Region0]. For [Scan3dExtraction0] the parameter specifies the number of 3D points in x-direction. The following combinations of SourceSelector and RegionSelector are permissible: - [Source0][Scan3dExtraction0] - [Source1/Source2][Region0]
Height[SourceSelector] [RegionSelector]	Height of the image provided by the device (in pixels).	The number of pixels in v-direction in the camera image [Region0]. For [Scan3dExtraction0] the parameter specifies the number of 3D points in x-direction. The following combinations of SourceSelector and RegionSelector are permissible: - [Source0][Scan3dExtraction0] - [Source1/Source2][Region0]
PixelFormat[SourceSelector] [RegionSelector] [ComponentSelector]	Format of the pixels provided by the device.	Indicates the pixel format used for the selected component. Pixel formats Mono8 and Mono16 are available for the [Intensity] components. You can select Mono16 or Coord3D_C32f for the 3D data [Range].
ComponentSelector [SourceSelector] [RegionSelector]	Selects a component to activate/deactivate its data streaming.	The following entries are available: - Intensity: Live camera image - Range: 3D data - Confidence: Mask for invalid points in 3D data - Amplitude: Amplitude image - PhaseGradient: Phase gradient image - Base: Image of the base intensities The following combinations of SourceSelector, RegionSelector and ComponentSelector are permitted: - [Source0][Scan3dExtraction0][Range] - [Source0][Scan3dExtraction0][Confidence] - [Source1/Source2][Region0][Intensity] - [Source1/Source2][Region0][Amplitude] - [Source1/Source2][Region0][PhaseGradient] - [Source1/Source2][Region0][Base]

Name	Description	Documentation Text
ComponentEnable [SourceSelector] [RegionSelector] [ComponentSelector]	Controls if the selected component streaming is active.	Describes the components to be transmitted. It is used in particular to distinguish between setup operation (live mode) and measurement mode. Setup operation is enabled, if only the [Intensity] component is enabled.
ImageScale[SourceSelector] [ComponentSelector]	2D Mode components only: Scale	Scaling factor for the gray values of the [Amplitude], [PhaseGradient] and [Base] components.
ImageOffset[SourceSelector] [ComponentSelector]	2D Mode components only: Offset	Offset for the gray values of the [Amplitude], [PhaseGradient] and [Base] components.
<b>Acquisition Control</b>		
AcquisitionMode	Sets the acquisition mode of the device.	Sets the mode for 3D image acquisition.  SingleFrame - single measurement, must be stopped using AcquisitionStop) (repeated measurement requires repeated AcquisitionStart). Continuous - continuous image acquisition (after AcquisitionStart) is performed until AcquisitionStop occurs.
AcquisitionStart	Starts the Acquisition of the device.	Starts image acquisition. If TriggerMode = Off, image acquisition starts immediately. If TriggerMode = On, the system waits for a trigger event.
AcquisitionStop	Stops the Acquisition of the device at the end of the current Frame.	Stops image acquisition once the current 3D frame has been transmitted in its entirety.
TriggerMode[TriggerSelector]	Controls if the selected trigger is active.	Enables trigger mode.
TriggerSoftware [TriggerSelector]	Generates an internal trigger. TriggerSource must be set to Software.	Command to trigger a measurement.
TriggerSource [TriggerSelector]	Specifies the internal signal or physical input Line to use as the trigger source.	Source of trigger signal. Available are Software (software trigger using Genicam command) and Line1 (hardware trigger from Input Line1).
TriggerActivation [TriggerSelector]	Specifies the activation mode of the trigger.	Sets whether the rising or falling slope of the trigger signal (only hardware trigger) is used to trigger a measurement.
ExposureTime	Sets the Exposure time in Microseconds.	The exposure time of the cameras in [ $\mu$ s].
PatternDisplay	Defines the pattern that is shown during live stream.	Selects the image to be projected by the projector for live image operation. The following entries are available: - Bright image - Off - Fringe pattern - Positioning aid
MultiSlopeMode	Controls multi-slope exposure state.	Controls the HDR mode: - Off: No HDR. - Manual: Manual HDR setting via the MultiSlopeKneePointCount and MultiSlopeExposureLimit registers - PresetSoft: Preset for light HDR effect (spreading of exposure times by a factor of 2). - PresetMedium: Preset for medium HDR effect (spreading of exposure times by a factor of 4). - PresetAggressive: Preset for medium HDR effect (spreading of exposure times by a factor of 8).

Name	Description	Documentation Text
<b>Measurement Control</b>		
GraycodeThreshold	Minimum allowed pattern contrast in the graycode images (for 3D reconstruction);	Only pixels whose gray value difference between the bright and dark images is equal to or greater than the limit value set are used for the calculation.
AmplitudeThreshold	Minimum allowed pattern contrast in the sinus images (for 3D reconstruction);	Only pixels whose amplitude value is greater than this threshold value are used to calculate the result. This allows you to exclude unwanted pixels with a low degree of reflection (e.g., outside the measured object or near the edges).
MaximumPhaseGradientEnable	Controls if threshold to sort out outliers is active.	Enables filtering of high gradient data in Z.
MaximumPhaseGradient	Threshold to sort out outliers in 3d point cloud.	Threshold for filtering with high gradient in Z.
MinimumIntensityThreshold	Threshold to sort out underdriven pixels.	Threshold for filtering of underexposed pixels.
MaximumIntensityThreshold	Threshold to sort out overdriven pixels.	Threshold for filtering of overexposed pixels.
PatternWidth	Sets the pattern period for sine pattern in pixel.	Strip width of the projected sine pattern.
PatternCount	Sets the number of patterns within one sine pattern sequence.	The number of sine patterns and images to be recorded which are used for one measurement.
PatternType	Selects the type of pattern projection.	Provides pre-defined options for setting the number of sine patterns and the images to be recorded that are used for one measurement: - HighSpeed: 4 - Standard: 12 - HighPrecision: 24 - Custom: Enables the user-specific PatternWidth and PatternCount registers
PerformanceMode	Boosts data processing speed while increasing internal temperature of sensor.	Significantly increases the data processing speed at the expense of the sensor's internal temperature. - On: The measurement speed will increase depending on the sensor settings by up to 85 %. - Off: The sensor's internal temperature can decrease by up to approx. 5 °C during continuous operation. The sensor can thus be operated in correspondingly higher ambient temperatures.
<b>Scan3dControl</b>		
Scan3dCoordinateSelector	Selects the individual coordinates in the vectors for 3D information/transformation.	Serves as a switch for the selected 3D coordinate.
Scan3dCoordinateScale [Scan3dExtractionSelector] [Scan3dCoordinateSelector]	Scale factor when transforming a pixel from relative coordinates to world coordinates.	Defines the distance between points in the measuring field [mm] in x and y direction. If the Mono16 format is used, scaling can be defined additionally for the z coordinate.
Scan3dCoordinateOffset [Scan3dExtractionSelector] [Scan3dCoordinateSelector]	Offset when transforming a pixel from relative coordinates to world coordinates.	Defines the offset of the point cloud in x and y direction [mm]. If the Mono16 format is used, the offset can be defined additionally for the z coordinate. The formula below can be used to transform the x and y indices into real world coordinates: $\text{Coord\_real} = \text{Scan3dCoordinateOffset}[\text{Scan3dCoordinateSelector}] + \text{index} * \text{Scan3dCoordinateScale}[\text{Scan3dCoordinateSelector}]$

Name	Description	Documentation Text
Scan3dExtractionMethod [Scan3dExtractionSelector]	Selects the method for extracting 3D from the input sensor data.	Defines the measuring mode: - Standard: Default measuring mode - EnhancedSNR: 3D calculation with double point density
Scan3dInvalidDataFlag [Scan3dExtractionSelector] [Scan3dCoordinateSelector]	Enables the definition of a non-valid flag value in the data stream.	Indicates whether the scan3dInvalidDataValue parameter can be used to identify invalid points. The value is "true" if no mask is transmitted.
Scan3dInvalidDataValue [Scan3dExtractionSelector] [Scan3dCoordinateSelector]	Value which identifies a non-valid pixel if Scan3dInvalidDataFlag is enabled.	If no mask is transmitted, this value defines the invalid points in the 3D data.
<b>Advanced3dControl</b>		
MaximumDeviation	Set the maximum deviation of a calculated 3d point based on the input data	Sets the value for the maximum deviation of a calculated 3D point based on the starting value (point cloud by gray code).
SearchStep	Search step in Millimeter	Sets the step width for searching the Z range.
ErroneousPoints	Defines the handling of an erroneous calculated 3d point (e.g. > MaximumDeviation)	Defines how incorrect 3D points are handled, e.g., when the maximum deviation is exceeded (see SearchStep). Erase - point is deleted and not output StartValue - start value from gray code calculation is used
LowerLimitZ	Lower limit of the measurement range (z axis)	Sets the lower limit of the measuring range on the Z axis. [mm]
UpperLimitZ	Upper limit of the measurement range (z axis)	Sets the upper limit of the measuring range on the Z axis. [mm]
RemoveNonAdjacents	Remove points with barely adjacent bindings whether they are single (no neighbor) or double (one neighbor).	To remove scattering points, you can specify whether only single points or also whole clusters of up to 8 points are to be removed. The '0' setting turns this option off. The value '1' removes all single points (without neighbors) and the default value '4' describes a cluster of up to 4 directly neighboring (clustered) points.
ReferencingActive	Specifies, whether the recently executed reference measurement (Nullung) is active.	Indicates whether the most recently performed reference measurement is active. To increase the accuracy of flatness measurements, a reference plane can be recorded. Correction data that are included when calculating 3D points are determined.
<b>LightControl</b>		
LightBrightness	Set the brightness of the lighting output in percent.	Sets the brightness of the LED in the projector. Note: In principle, the exposure time should first be reduced as much as possible if there is overexposure.
<b>Event Control</b>		
EventFrameTriggerData	Category that contains all the data features related to the FrameTrigger Event.	This event is triggered when a trigger has been initiated.
EventFrameTrigger	Returns the unique Identifier of the FrameTrigger type of Event.	This event is triggered when a trigger has been initiated.

Name	Description	Documentation Text
EventFrameTriggerMissedData	Category that contains all the data features related to the FrameTriggerMissed Event.	This event is triggered when a measurement is triggered although the most recent measurement has not yet been completed.
EventFrameTriggerMissed	Returns the unique Identifier of the FrameTriggerMissed type of Event.	This event is triggered when a measurement is triggered although the most recent measurement has not yet been completed.
EventExposureEndData	Category that contains all the data features related to the ExposureEnd Event.	This event is triggered when image acquisition for a measurement has been completed and calculation of the 3D results is started. The sensor or measuring object can now be moved to the next measuring position.
EventExposureEnd	Returns the unique identifier of the ExposureEnd type of Event.	This event is triggered when image acquisition for a measurement has been completed and calculation of the 3D results is started. The sensor or measuring object can now be moved to the next measuring position.
EventFrameStartData	Category that contains all the data features related to the FrameStart Event.	This event is triggered when the measurement is started.
EventFrameStart	Returns the unique identifier of the FrameStart type of Event.	This event is triggered when the measurement is started.
EventFrameEndData	Category that contains all the data features related to the FrameEnd Event.	This event is triggered when the measurement is completed.
EventFrameEnd	Returns the unique identifier of the FrameEnd type of Event.	This event is triggered when the measurement is completed.
EventWarningData	Category that contains all the data features related to the Warning Event.	This event is triggered when a warning occurs during the measurement.
EventWarning	Returns the unique identifier of the Warning type of Event.	This event is triggered when a warning occurs during the measurement.
EventWarningCode	Returns an warning code for the warning(s) that happened.	This parameter returns the warning type for a warning. The following warning codes are possible: - 1: Warning: Device temperature is becoming critical.
EventWarningMessage	Returns a detailed message for the warning.	In addition to the warning, an additional description of the warning is returned if necessary.
EventErrorData	Category that contains all the data features related to the Error Event.	This event is triggered when an error occurs during the measurement.
EventError	Returns the unique identifier of the Error type of Event.	This event is triggered when an error occurs during the measurement.

Name	Description	Documentation Text
EventErrorCode	Returns an error code for the error(s) that happened.	This parameter returns the defect type for a measuring error. The following error codes are possible: - 1: Error Sensor Hardware: An error occurred in a hardware component in the sensor. Contact Micro-Epsilon. - 2: Error Sensor Acquisition: An error occurred during data acquisition in the sensor. Contact Micro-Epsilon. - 3: Error 3D Reconstruction: The 3D reconstruction could not be calculated. - 9: Error Critical Temperature: As temperatures are too high, further measurements are prevented.
EventErrorMessage	Returns a detailed message for the error.	In addition to the error type, an additional description of the measuring error is returned if necessary.
<b>User Set Control</b>		
UserSetSelector	Selects the feature User Set to load, save or configure. Default = factory settings	Selects the user settings function for loading, saving or configuring. Here, Default means default settings.
UserSetLoad[UserSetSelector]	Loads the User Set specified by UserSetSelector to the device and makes it active.	Loads the user setting specified by ""UserSetSelector"" into the sensor and enables it.
UserSetSave[UserSetSelector]	Save the User Set specified by UserSetSelector to the non-volatile memory of the device.	Saves the user setting specified by ""UserSetSelector"" to the sensor.
UserSetDefault	Selects the feature User Set to load and make active by default when the device is reset. Default = factory settings	Selects the user setting that is loaded and enabled by default when the sensor is reset. Here, Default means factory settings.
<b>DigitalIO Control</b>		
LineSelector	Selects the physical line (or pin) of the external device connector or the virtual line of the Transport Layer to configure.	Selection of the GPIO port to be configured.
LineMode[LineSelector]	Controls if the physical Line is used to Input or Output a signal.	Defines whether the selected GPIO port is an input or output.
LineInverter[LineSelector]	Controls the inversion of the signal of the selected input or output Line.	Enables inverting of the input or output signal for the selected GPIO port.
LineStatus[LineSelector]	Returns the current status of the selected input or output Line.	Queries the status of the selected GPIO port.
LineStatusAll	Returns the current status of all available Line signals at time of polling in a single bitfield.	Outputs the current status of all digital in-/outputs.



Name	Description	Documentation Text
LineSource[LineSelector]	Selects which internal acquisition or I/O source signal to output on the selected Line.	Selects the internal source for the output signal of the selected GPIO port.



MICRO-EPSILON MESSTECHNIK GmbH & Co. KG  
Königbacher Str. 15 · 94496 Ortenburg/Germany  
Phone +49 8542 / 168 0 · Fax +49 8542 / 168 90  
info@micro-epsilon.de · www.micro-epsilon.de  
Your local contact: [www.micro-epsilon.com/contact/worldwide/](http://www.micro-epsilon.com/contact/worldwide/)

X9751439-A012012MSC  
© MICRO-EPSILON MESSTECHNIK