

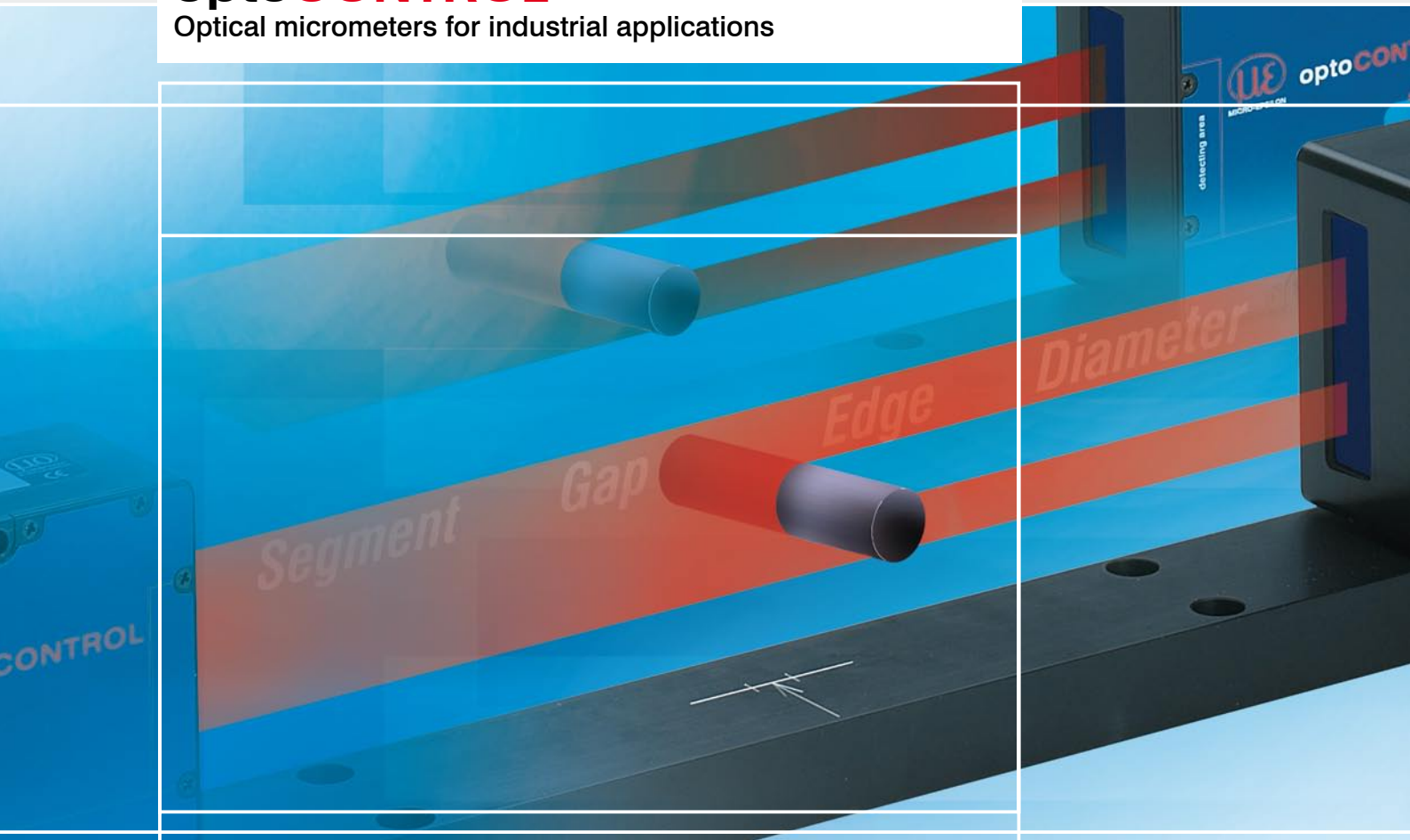

# More Precision.

## **optoCONTROL**

Optical micrometers for industrial applications



## Optical micrometers for high precision applications



### Optical precision micrometers

Micrometers from Micro-Epsilon operate according to the ThruBeam principle. Here, the transmitter produces a parallel light curtain that is transmitted via a lens arrangement into the receiving unit. The beam is interrupted if there is an object in the light path. The shadowing generated by this object is recorded by the receiving optical system and output as a geometric value.

Several types of ThruBeam technology are used across the four different sensor models in the range so as to cover as wide a field of applications as possible.

Optical micrometers can be used for dimensional measurements in production, quality assurance and service tasks. Factors such as the diameter, gap, height, position and also the received amount of light or opacity can be measured.

- High accuracy and measuring rate
- Different models for numerous application areas
- Measurement objects from 0.02mm
- Wear-free measurement for long service life

### Wear-free and long service life

All optoCONTROL sensors function without a rotating mirror and so are completely wear-free. The parallel light curtain is produced by a special lens arrangement in the light source (transmitter). High quality components in the receiving optical system, e.g. filter and lenses, enable high accuracies to be achieved. Therefore, the optoCONTROL micrometers are ideally suited to applications in which high precision and complete reliability are required.

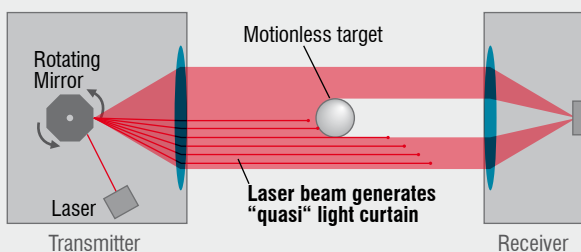

 **Common micrometers with rotating mirror:**  
No true profile can be generated through delayed laser curtain

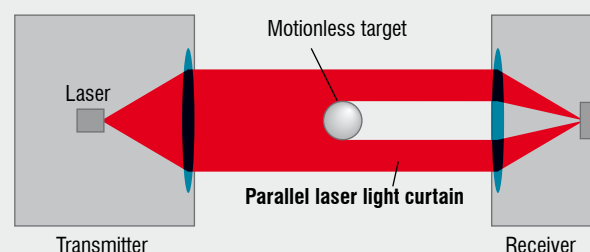

 **optoCONTROL wear free thru-beam micrometers:**  
High speed real time consistent data enables true precision profile without distortion

	Measuring ranges	Measurement mode
Page 4 - 5 optoCONTROL 1200 Compact, fast and space-saving 90° version; integrated controller	Measuring range up to 30mm	
Page 6 - 7 optoCONTROL 1202 Target-sensor gap up to 2000mm Integrated controller	Measuring range up to 98mm	
Page 8 - 9 optoCONTROL 2500 High accuracy and stability Camera-light source gap up to 700mm	Measuring range up to 34mm	
Page 10 - 11 optoCONTROL 2600 Maximum accuracy and stability Target-sensor gap up to 150mm	Measuring range up to 40mm	

**Flexible operation**

Micrometers are normally used for production control and to monitor the quality of continuous web and strip based material and individual products within production lines. The three technologies used – laser intensity measurement, laser shadowing and LED light – are suitable for a wide range of applications.

The compact optoCONTROL models are equally suitable for applications on the production line as well as for integration in machines and automated production equipment. The high measuring rates ensure a high, continuous productivity rate in the production process.

**Special application areas**

The optoCONTROL 2500 and 2600 model ranges can be modified for customer specific applications, for example:

- Carry case version for service tasks
- Customised cable lengths, modified cable outlet
- Version with reduced light source to receiver gap
- Version with deflection mirror for installation in tight spaces
- Customer-specific software, e.g. measurement programmes, statistics

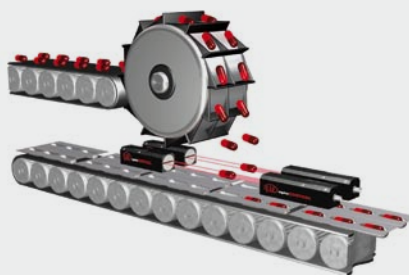

Miniature version for tight installation spaces

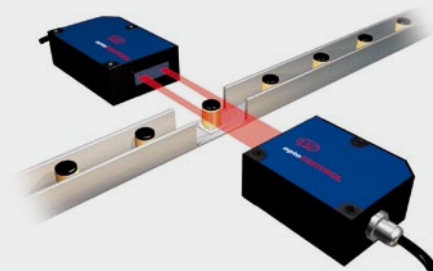

For fast measurement processes

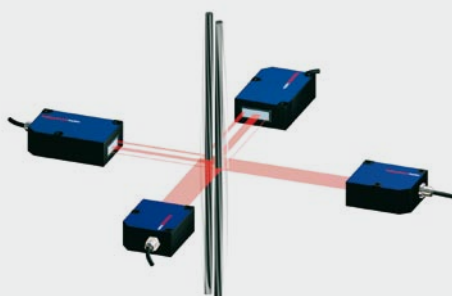

For small targets from 0.3mm

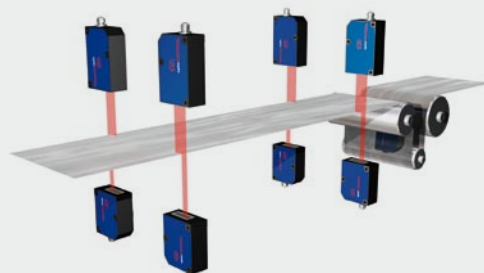

For synchronous applications

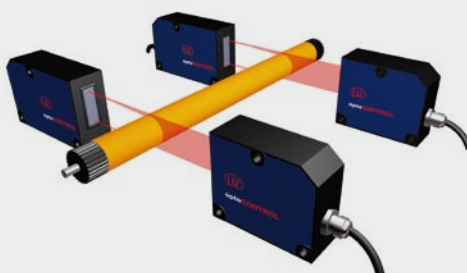

For large targets up to 98mm

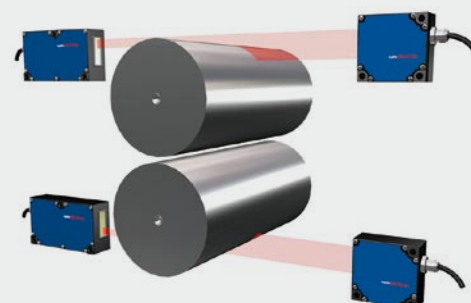

For precise measurements



### Measuring principle

The optoCONTROL 1200 is based on the principle of light quantity measurement. The light of a red laser diode is spread out by a lens to a parallel light curtain which is aimed at the receiving unit. In the receiving unit, the light is guided via various filters and lenses through a precision shutter to a light-sensitive detector. The amount of occurring light is provided by analogue electronics and output as an analogue signal.

### System design

optoCONTROL 1200 consists of a light source and a receiving unit. The complete controller electronics are integrated in the receiver housing. The light source and receiver can be installed at any distance up to 5 metres from each other. All models can be installed without additional brackets in both vertical and horizontal positions. The compact design of the housing and the 90° version also enable easy mounting of the miniature micrometers in tight installation spaces.

As well as the analogue output, an adjustable limit switch is also available. This can be operated both as NPN (bright switching) as well as in PNP logic (dark switching).

### Measurement mode

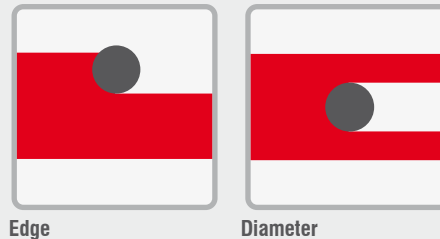

Edge

Diameter

The target must be positioned inside the measuring window for the diameter measurement. Smallest diameter 0.3mm

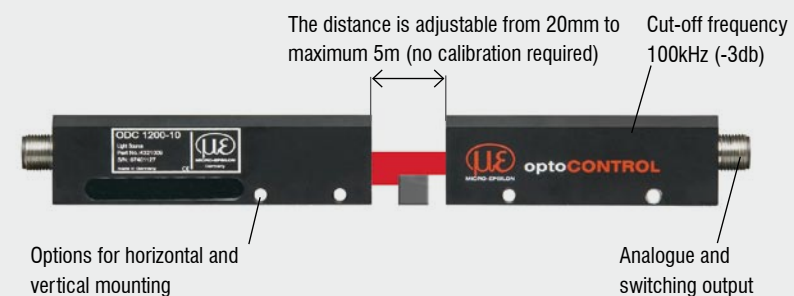

The distance is adjustable from 20mm to maximum 5m (no calibration required)

Cut-off frequency 100kHz (-3dB)

Options for horizontal and vertical mounting

Analogue and switching output

optoCONTROL 1200/90: Version with 90° beam path for mounting in tight spaces



### Special features

- High quality glass lense optics
- Extremely fast 100kHz (-3dB)
- Robust and compact design with integrated controller
- Limit switch with up to 25kHz switching frequency
- Axial and radial design

Model	ODC 1200 (axial model)				ODC 1200/90 (90° model)				ODC 1201		
Measuring range	2mm	5mm	10mm	16mm	2mm	5mm	10mm	16mm	20mm	30mm	
Distance transmitter - receiver	min. 20mm to max. 5m										
Independent linearity	±2% FSO		±3.5% FSO		±2% FSO		±3.5% FSO				
Resolution (dynamic)	10µm	25µm	50µm	80µm	10µm	25µm	50µm	80µm	100µm	150µm	
Frequency response	100kHz (-3db)										
Light source	semiconductor laser < 1mW, 670nm (red, laser class 2)										
Permissible ambient light	≤ 5000lx										
Analogue output	0 ... 10VDC (gain adjustable)										
Switching output (max switching frequency 25 kHz)	PNP active if light quantity below limit; NPN active if light quantity above limit										
Shock	15 g / 6 ms (IEC 68-2-29)										
Vibration	15 g / 10 Hz...1 kHz										
Operation temperature	0 to 50°C										
Storage temperature	-20 to 70°C										
Operation voltage	12 ... 32VDC, reverse polarity protection										
Mounting holes	straight up								M4 x 5mm		ø4.1mm
	horizontal								M5 x 8mm		M4 x 6mm
Weight (without cable)	transmitter	appr. 150g				appr. 170g				appr. 260g	
	receiver	appr. 120g				appr. 160g				appr. 220g	
Protection class	IP 67										

FSO = Full Scale Output

The quoted data apply for a constant room temperature of 20°C after a warm-up period of 30 min, in the range 10 ... 90% of the analogue output at a distance between transmitter and receiver of 0.5 m.

Analogue drift 0.12 V at constant temperature; If laser beam is covered (without ambient light): analogue offset < 0.05 V

### optoCONTROL 1200

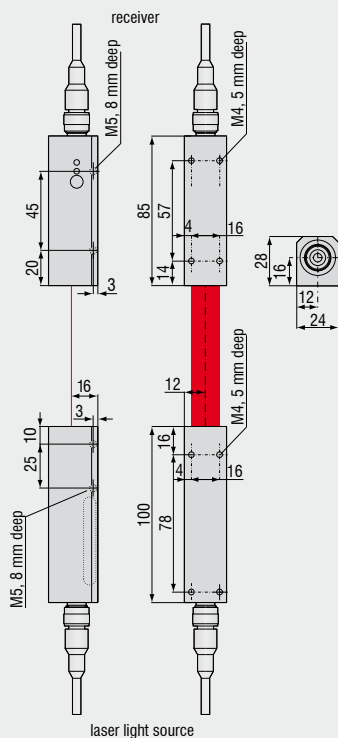

### optoCONTROL 1200/90

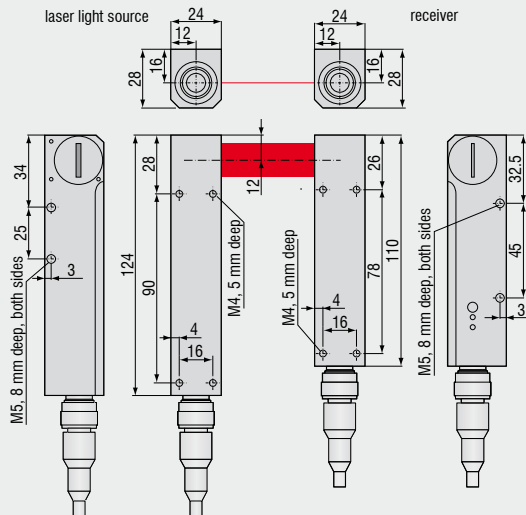

### optoCONTROL 1201

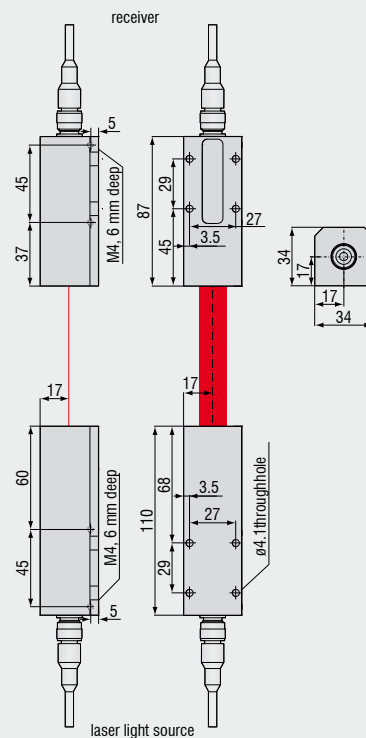



### Measuring principle

The laser beam for the optoCONTROL 1202 laser micrometers is output from the optical transmitter as a parallel aimed laser beam. The laser line strikes a CCD array in the receiving optical system. The amount of light collected by each of these receiving elements during the integration time is read out separately as analogue voltage and stored as a digital value in a data field after analogue-to-digital conversion.

If there is a non-transparent measurement object in the laser line, only the receiving elements of the lines outside the shadow zone of the measurement object are illuminated. As the spacing of the pixels of the CCD array is known, the size and position of the measurement object can be determined.

### System design

optoCONTROL consists of a light source and a receiving unit. The complete controller electronics are integrated in the receiver housing. The light source and receiver can be installed at any distance from each other. All models can be installed without additional brackets in both the vertical and horizontal positions.

### Measurement mode

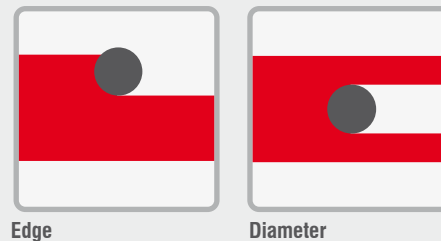

Edge

Diameter

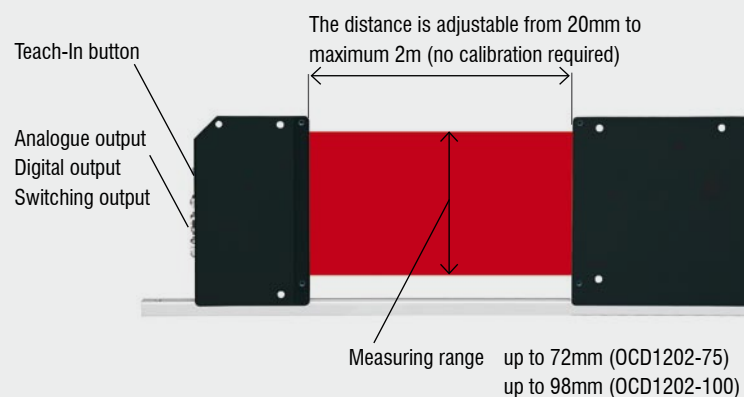

### Special features

- High resolution CCD array detector with integrated controller
- Measuring range up to 98mm
- Measuring distance selectable from 20 to 2000mm
- Integrated polarisation filter / interference filter
- One digital input (start trigger)
- Two digital outputs, one analogue output (0 – 10V)



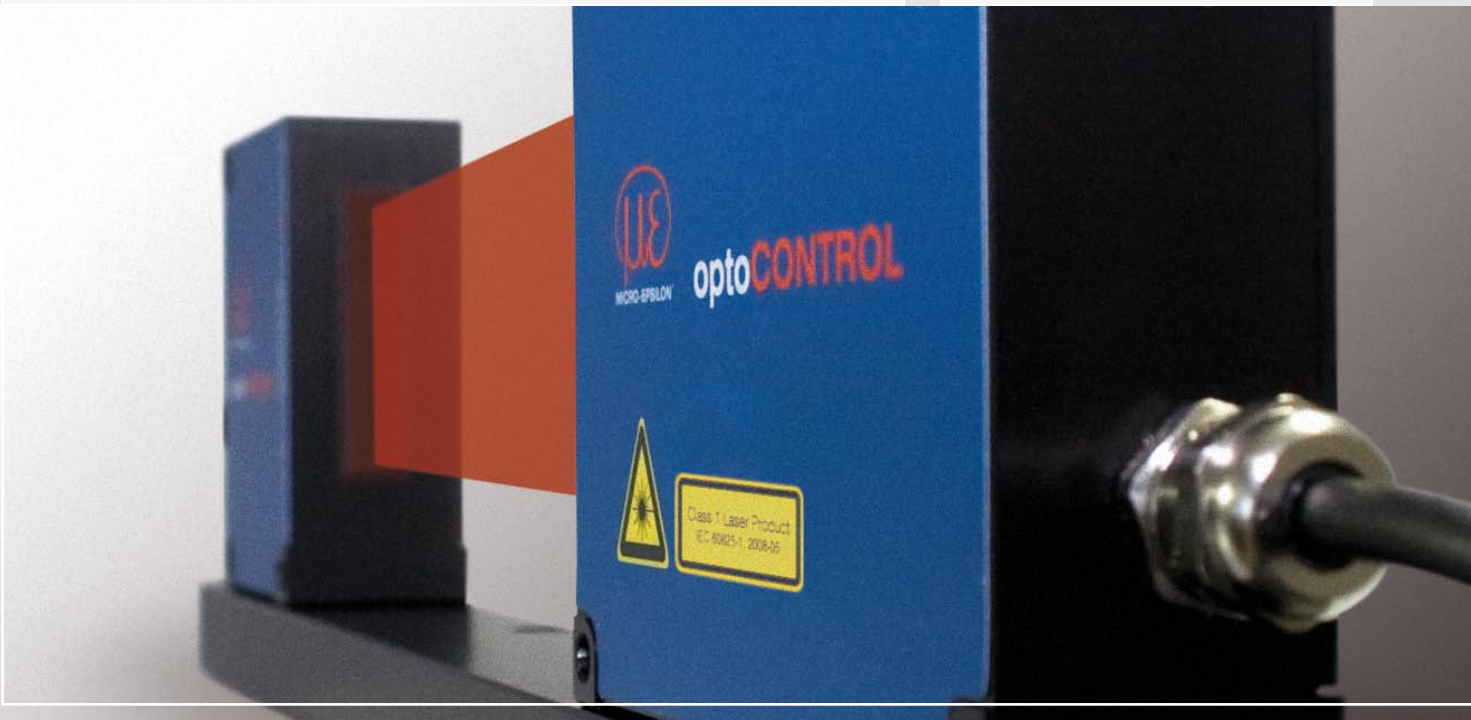

### Measuring principle

optoCONTROL 2500 is a laser-based measuring system with integrated high resolution CCD camera. The ThruBeam micrometer measures the dimension of an object or the position of an edge by using the shadow-casting principle. The data obtained with various, selectable measuring programmes is output via analogue and digital interfaces. Thanks to the high measuring rate, the outstanding accuracy and excellent resolution, the laser micrometer is ideally suited to precision measurement and inspection tasks on moving products in production lines.

### System design

optoCONTROL 2500 consists of a sensor unit and a controller. The sensor unit comprises a laser light source (transmitter) and a CCD camera (receiver). A parallel light curtain is produced with the laser light source. The CCD array in the receiver measures the contour formed by shadow casting of the measurement object with high accuracy. The sensor unit is controlled and evaluated by an intelligent controller with graphical display for operation and display of the measured values.

### Predefined measurement modes (six individual programmes can be selected)

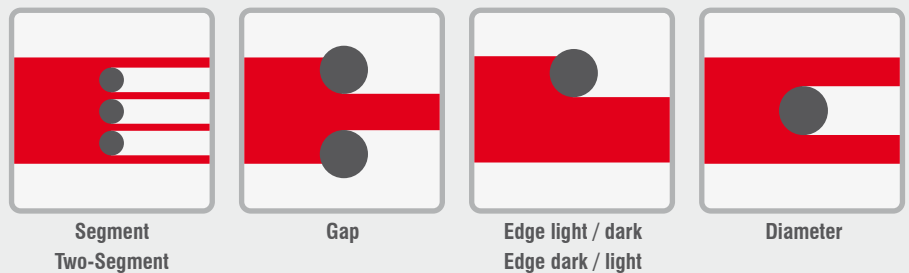

Segment  
Two-Segment

Gap

Edge light / dark  
Edge dark / light

Diameter

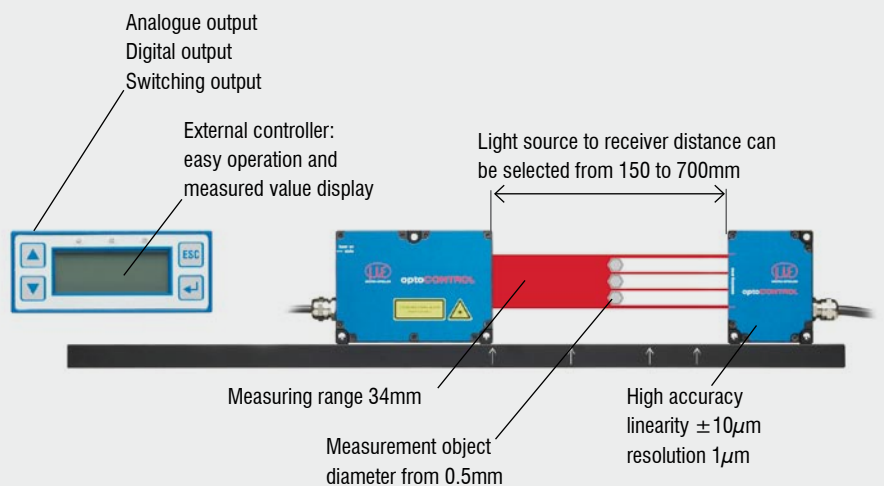

### Special features

- High resolution and precision
- Measuring rate 2.3kHz for fast processes
- Laser-ThruBeam technology
- Six different measuring programmes

Model		ODC 2500-35
Measuring range		34mm
Smallest diameter (detectable target)		0.5mm
Distance lightsource - CCD-camera		300mm (150mm - 700mm)
Distance (target to receiver)		20 ... 150mm
Linearity <sup>1)</sup>		±10µm
Resolution <sup>2)</sup>		1µm
Repeatability		≤3µm
Sampling rate		2.3kHz
Light source		semiconductor laser 670nm, class 1
Analogue output		0 ... 10V, range -10 ... + 10V
Digital output		RS 232 or RS 422
Switching output		1 x error, 2 x limit, 2 x warning; LC-Display, 3 x LED; Sync-Out
Input		sync-In; zero ; Laser On/Off
Operating temperature		0°C to 50°C
Storage temperature		-20°C to 70°C
Supply voltage		24VDC (± 15%)
Vibration		acc. IEC 60068-2-6 2g / 20 ... 500Hz
Shock		acc. IEC 60068-2-29 15g / 6ms
Cable length		2m (option: extension 3m/8m)
Protection class	receiver / light source	IP 64
	controller	IP 40
Display	LC-display (value, maximum, minimum, peak-to-peak) display in mm or inch, selectable; menu languages in german / english, selectable 3x LED (power on, light on, error)	
Measuring programmes	diameter, gap, position / edge, segment, two-segment	

All specifications are measured at a constant temperature of 20 °C after a warm-up time of 30 minutes.

<sup>1)</sup> Valid for distance of the target to receiver 20±5 mm; Distance lightsource - CCD-camera 150mm

<sup>2)</sup> Display resolution

#### Customer specific versions

- Carry case version for service tasks
- Customised cable lengths, modified cable outlet
- Version with reduced light source to receiver gap
- Version with deflection mirror for installation in restricted, tight spaces

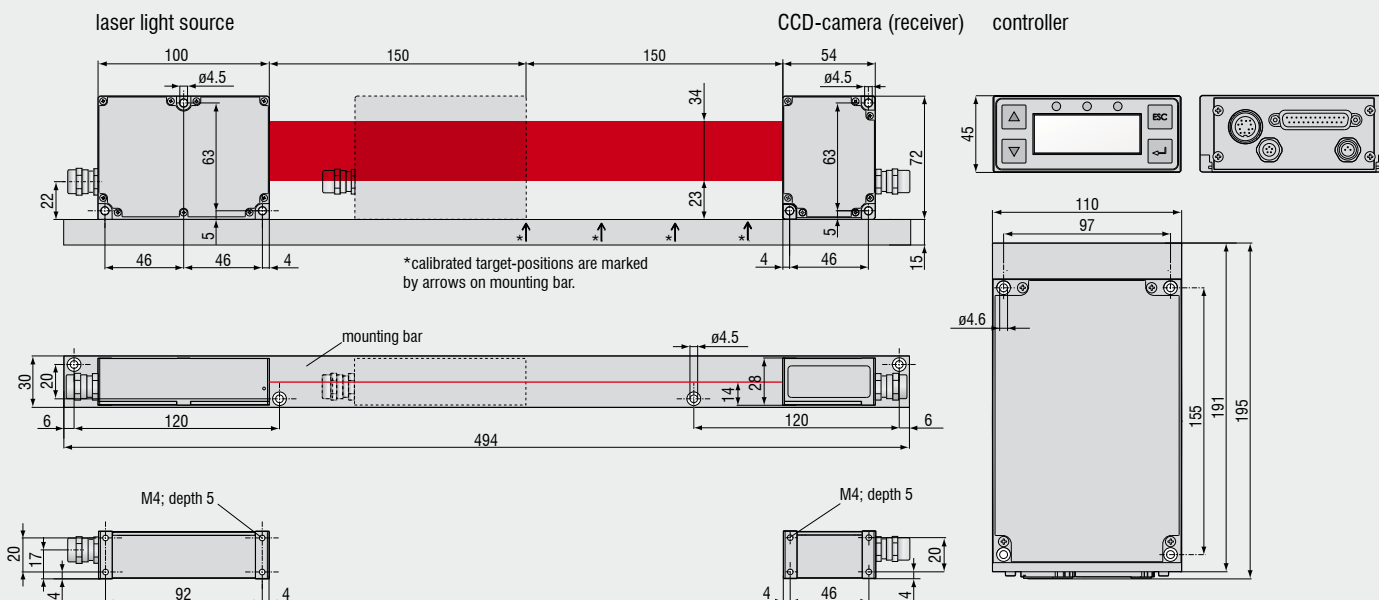

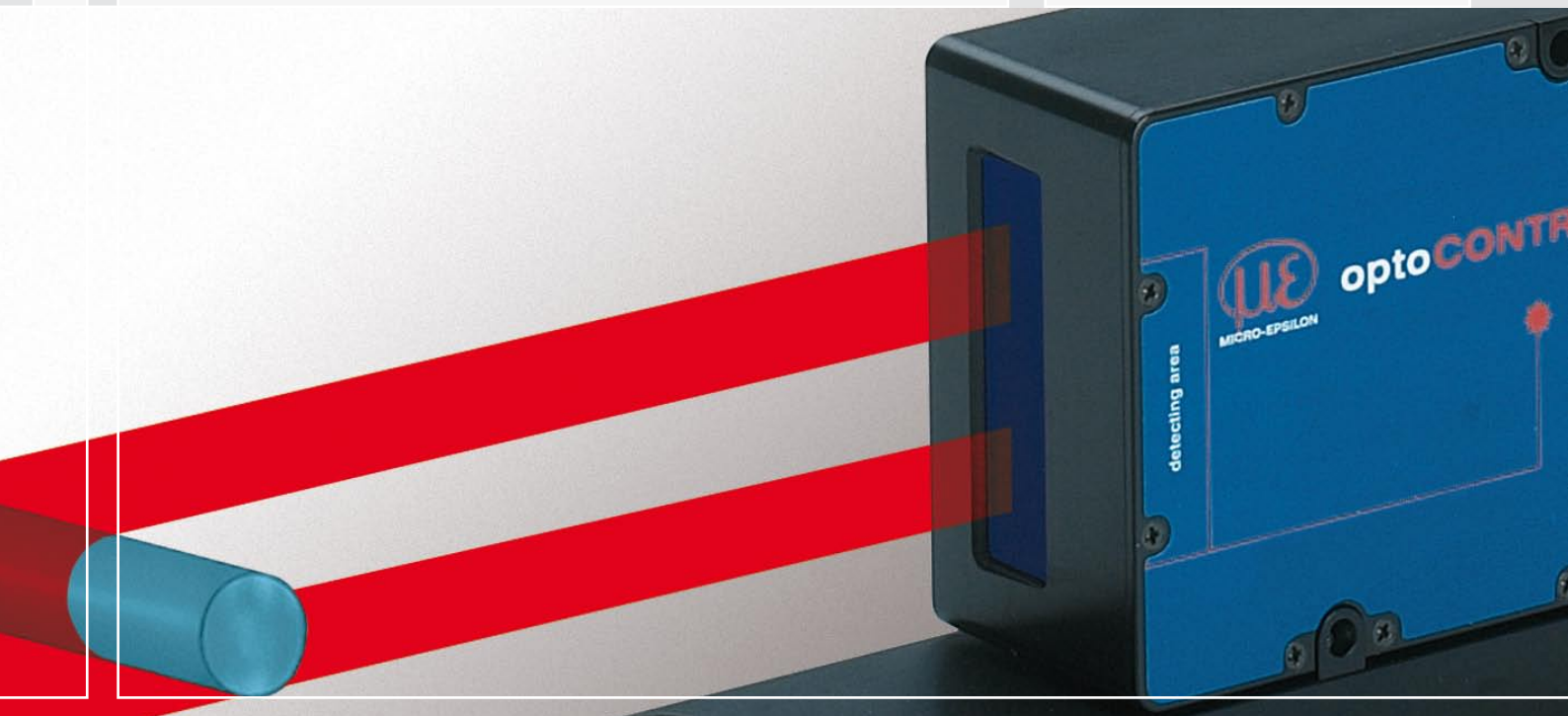

### Measuring principle

optoCONTROL 2600 is an optical measuring system with integrated high resolution CCD camera. Using a special lens arrangement, an LED light source produces a parallel light curtain (visible red light), which is imaged on the CCD camera via a telecentric lens. If an object to be measured is placed in the light curtain, the shadow it creates is detected by the CCD array. The measured data is output via analogue and digital interfaces.

### System design

optoCONTROL 2600 consists of a sensor unit and a controller, which are attached to a mounting rail. The sensor unit comprises a light source with high power LED and a receiver with telecentric lens and CCD array. The sensor unit is controlled and evaluated by an intelligent controller with graphical display for operation and display of the measured value. The adjustable light source enables precise measurement of most transparent objects. Significantly higher accuracies and repeatability of measured data is made possible due to the combination of LED with telecentric lens arrangement. The system is insensitive to high external light conditions.

### Predefined measurement modes (six individual programmes can be generated)

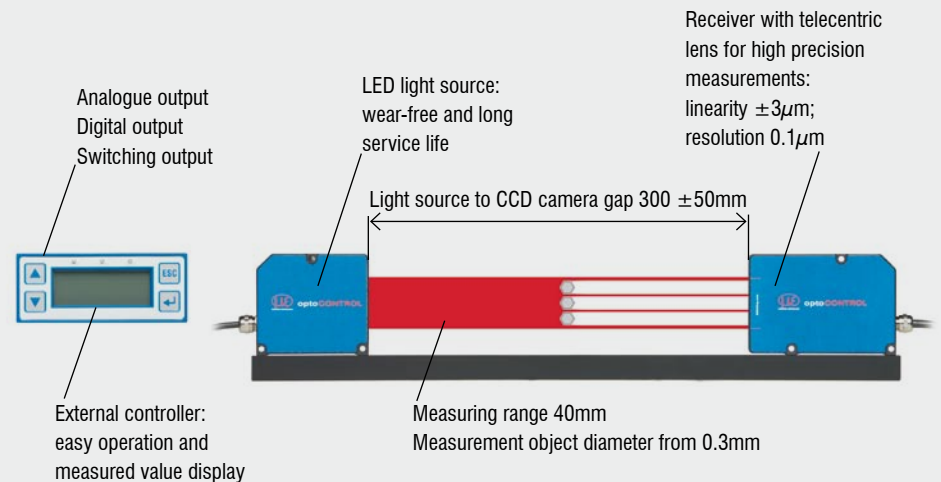
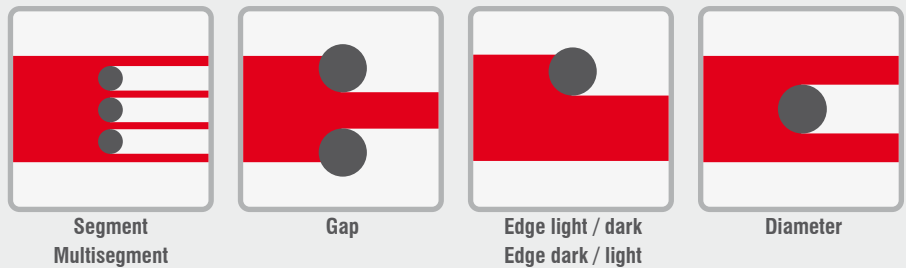

### Special features

- Maximum resolution and accuracy
- Outstanding repeatability
- Measuring rate 2.3kHz for fast processes
- High resistance to dirt and moisture
- Measurement against glass and transparent plastics
- Six different measuring programmes

Model	ODC2600-40	
Measuring range	40mm	
Smallest diameter (detectable target)	0.3mm	
Distance lightsource - CCD-camera	300 (±50)mm	
Distance (target to receiver)	150 (±5)mm	
Linearity (3s) <sup>1)</sup>	< ±3µm	
Resolution <sup>2)</sup>	0.1µm	
Repeatability	±1µm	
Sampling rate	2.3kHz	
Light source	red LED	
Analogue output (voltage)	0 ... 10VDC, range ±10VDC, selectable <sup>3)</sup>	
Digital output	RS232 (115.2kBaud) or RS422 (691.2kBaud)	
Switching output	error, 4x limit, synchronisation	
Input	zero; reset; trigger; synchronisation; light on/off (programmable)	
Operation temperature	0°C to 50°C	
Storage temperature	-20°C to 70°C	
Supply voltage	24VDC (±15%), < 1A	
Vibration	acc. IEC 60068-2-6 2g / 20 ... 500Hz	
Shock	acc. IEC 60068-2-29 15g / 6ms	
Cable length (controller-transmitter / controller-CCD-camera)	Standard: 2m	
Protection class	receiver / light source	IP 64
	controller	IP 40
Measuring programmes	edge light-dark; edge dark-light; diameter; gap; segment; multi-segments; 4 user-programs	
Display	LC-display (value, maximum, minimum, peak-to-peak); display in mm or inch, selectable; menu languages in german / english, selectable; 3x LED (power on, light on, error)	

All specifications are measured at a constant temperature of 20°C after a warm-up time of 30 minutes.

<sup>1)</sup> Edge measurement at 2.3kHz, no averaging at the target, operating distance 150 ±5mm.

<sup>2)</sup> Display resolution (resolution digital output 0.6µm)

<sup>3)</sup> The gain of the analogue output can be increased to a max. of 10V / 10mm respectively 10V / 20mm (analogue gain 4) then 0.3µm resolution.

#### Optional versions

- Carry case version for service tasks
- Customised cable lengths, modified cable outlet
- Customer-specific software (measuring programmes, statistics)
- Version with deflection mirror for installation in restricted spaces

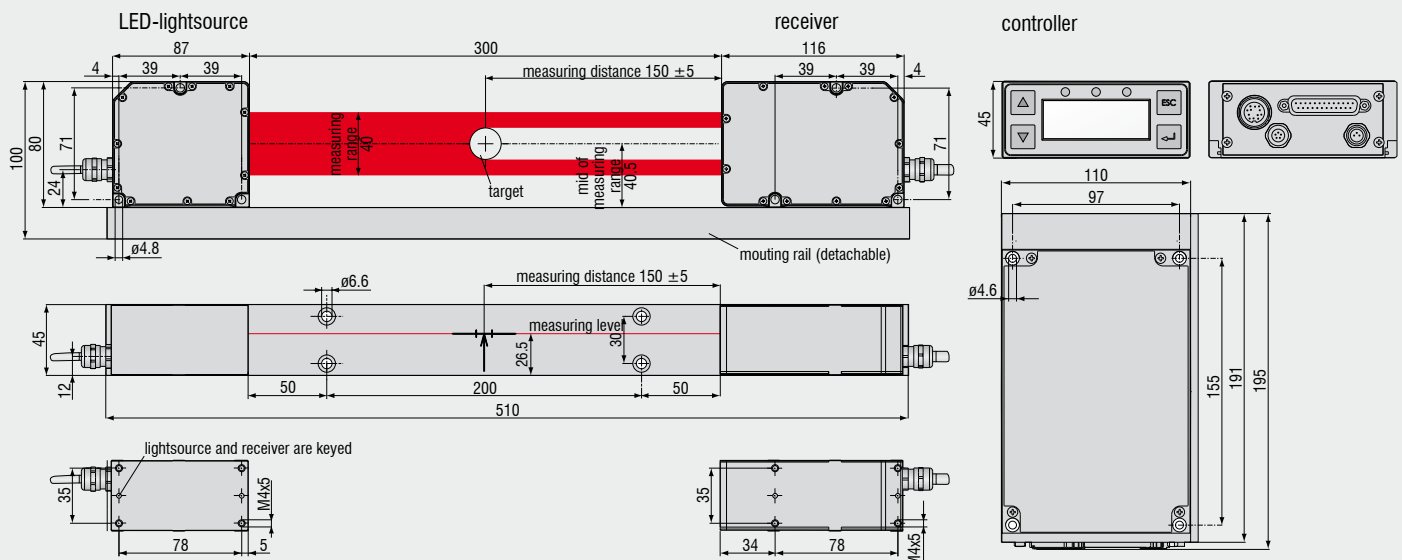

### Measurements with several micrometers

- Thickness measurement
- Level measurement
- Width measurements
- Planarity measurements
- Edge determination
- Diameter measurement

#### Interface card IF 2008 for synchronous data recording

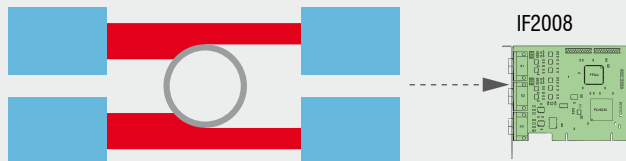

Up to six digital signals, two analogue signals, two encoders

The IF 2008 interface card is designed for installation in PCs and enables the synchronous capture of up to six digital sensor signals, two analogue sensor signals and two encoders. The card is used for the customer's own data evaluation. The interface card reads the data from all connected devices simultaneously and transmits these to an external PC for further processing.

#### CSP 2008: universal controller for multiple sensor signals

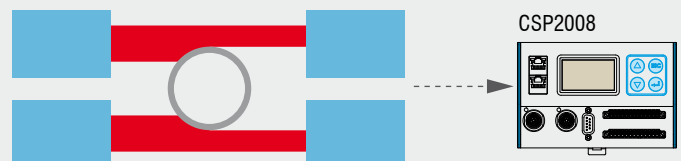

Two to six analogue or digital signals

The CSP2008 controller is used for processing at least two, maximum of six digital or analogue input signals (2 x internal + 4 x external via EtherCAT modules from Beckhoff). EtherCAT is also envisaged as the external interface for connecting further sensors and I/O modules. The controller has a display with multi-coloured backlighting, which changes colour when pre-set limits have been exceeded or alarms have been programmed.

Calculation:

A,B; A+B; A-B; -A-B; K-A-B; K+A+B;  
K+A-B; K+A; K+B; K(A+B); K(A+k\*B)

#### Accessories for optoCONTROL 1200/1201/1202

Art. No.	Modell	
2901260	PC1200-5	Power supply and signal cable 5m, straight connector, for light source and receiver unit
2901261	PC1200/90-5	Power supply and signal cable 5m, angled connector, for light source and receiver unit
2420019	PS2010	Power supply for DIN rail mounting, input 230VAC, output 24V DC/2.5 A
2901497	CE1202-2	Connecting cable transmitter-receiver, 2m
2901482	CE1202-5	Connecting cable transmitter-receiver, 5m
2901371	SCD1202-2	Digital output cable, 2m, for connection to a RS232 port
2901509	SCD1202-5	Digital output cable, 5m, for connection to a RS232 port
2901373	SCA1202-2	Power supply and analogue output cable, 2m
2901510	SCA1202-5	Power supply and analogue output cable, 5m

#### Accessories for optoCONTROL 2500/2600

2420057	CSP2008	Universal controller for multiple signals
2213017	IF2008	PCI interface card RS422
2901057	CE1800-3	Sensor cable extension for camera, 3m
2901118	CE2500-3	Sensor cable extension for light source, 3m
2901058	CE1800-8	Sensor cable extension for camera, 8m
2901119	CE2500-8	Sensor cable extension for light source, 8m
2901120	SCA2500-3	3 Signal output cable, analogue, 3m
2901121	SCD2500-3/3/RS232	Signal output cable 3m, for RS232
2901122	SCD2500-3/10/RS422	Signal output cable 3m / RS422 10m
2901123	PC2500-3	Power supply cable 3m
2901124	PC2500-10	Power supply cable 10m
2901504	SCD2500-3/CSP	Power supply and output cable 3m, for connection to CSP2008
2901505	SCD2500-10/CSP	Power supply and output cable 10m, for connection to CSP2008
2901122	SCD2500-3/10/RS422	Output cable with RS422, 3 or 10m, for connection to IF2008