











# More Precision

**optoNCDT** // Laser displacement sensors (triangulation)



# Smart laser sensors for precise measurements optoNCDT 1900

designed for advanced  
**AUTOMATION**

-  For common surfaces
-  Measuring rate up to 10 kHz
-  **INTERFACE** Analog (U/I) / RS422 / PROFINET / EtherNet/IP / EtherCAT
-  **ASc** Advanced Surface Compensation
-  Repeatability  $<0.1 \mu\text{m}$
-  Ideal for series and OEM applications
-  Highest immunity to ambient light
-  High resistance to shocks and vibrations



## Next-generation laser sensors

The optoNCDT 1900 laser sensors are used for dynamic displacement, distance and position measurements and offer a unique combination of performance, design and integration capability. The integrated high-performance controller enables fast and highly precise processing and output of measurement values.

These innovative sensors are used whenever maximum precision is combined with the latest technology, e.g., in sophisticated automation, automotive production, 3D printing and coordinate measuring machines.

## Advanced Surface Compensation – The intelligent exposure control for demanding surfaces

The optoNCDT 1900 laser sensors are equipped with an intelligent surface control feature. Innovative algorithms enable stable measurement results even on demanding surfaces where changing reflections occur. Furthermore, these new algorithms compensate for ambient light up to 50,000 lux. Therefore, these are the sensors with the highest resistance to ambient light in their class and can even be used in strongly illuminated environments.

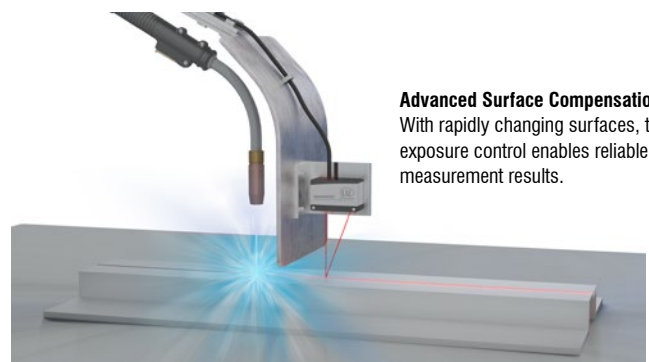

**Advanced Surface Compensation**  
With rapidly changing surfaces, the exposure control enables reliable measurement results.

## Industrial Ethernet for easy integration



The latest optoNCDT 1900 laser triangulation sensors are also available with integrated Industrial Ethernet interface. Depending on the model, you can integrate the full sensor performance into your PLC directly via EtherCAT, EtherNet/IP or PROFINET without any additional interface module. You benefit from real-time data without time delay as well as reduced installation and wiring effort.

The sensor parameters can be set directly via Industrial Ethernet or still via web interface. For high speed measurements, the sensor offers an Oversampling feature which allows, depending on the fieldbus, measurement data to be detected or transmitted eight times faster than the bus cycles.

EtherCAT®

EtherNet/IP®

PROFINET®

Model	Technology	Measuring range	Repeatability	Linearity
optoNCDT 1900		2 - 500 mm	0.1 $\mu\text{m}$	from 0.02 %
optoNCDT 1900LL		2 - 50 mm	0.1 $\mu\text{m}$	from 0.02 %

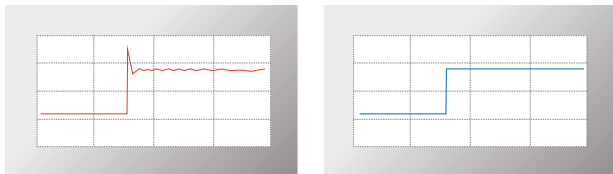
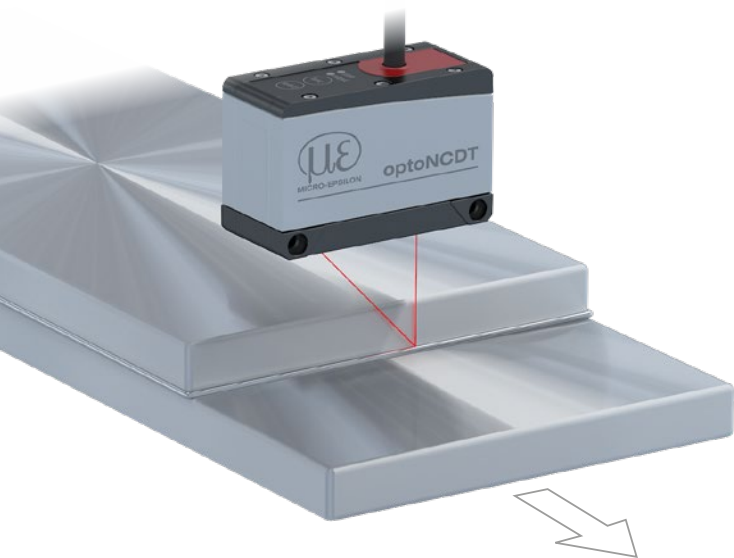

The two-step measurement value averaging enables smooth signal courses when measuring edges (right). Otherwise, interfering signals occur (left).

### Highest stability based on intelligent signal optimization

For the first time, a two-step measurement value averaging feature is available to optimize the signal. This enables a smooth signal at edges and steps. Especially for high speed measurements of moving parts, measurement averaging enables a precise signal course.

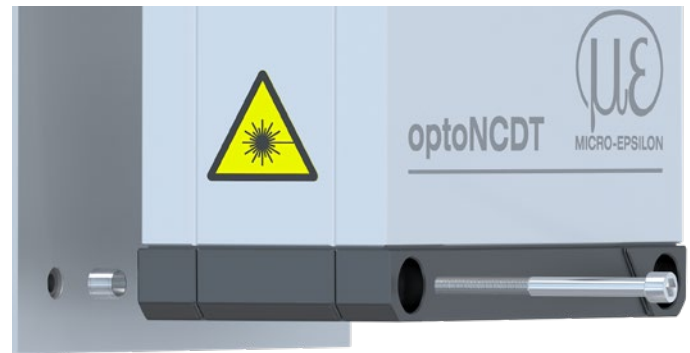

### Patented installation

Easy mounting and high repeatability when replacing the sensor

### Simple mounting and initial operation

Mounting the sensor using fitting sleeves automatically aligns the sensor in the correct position. This enables both easy sensor replacement and even higher precision in solving measurement tasks. Thanks to its small dimensions, the laser sensor can also be integrated in confined spaces.

## Application examples

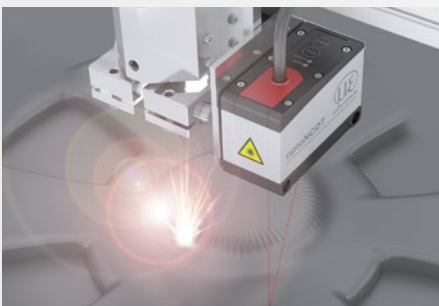

Distance measurement of print heads

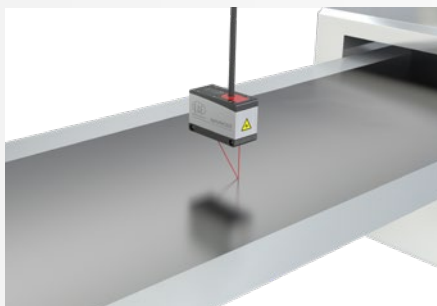

Thickness measurement of electrode film

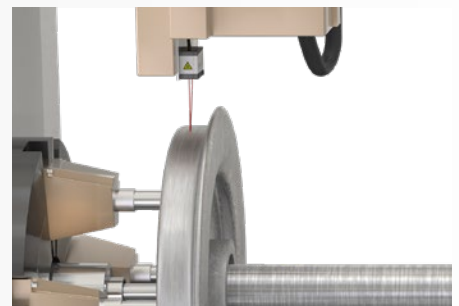

Wear inspection of wheel tires



## Laser-Line - optoNCDT 1900LL

Model	ILD1900-2LL	ILD1900-6LL	ILD1900-10LL	ILD1900-25LL	ILD1900-50LL	
Measuring range	2 mm	6 mm	10 mm	25 mm	50 mm	
Start of measuring range	15 mm	17 mm	20 mm	25 mm	40 mm	
Mid of measuring range	16 mm	20 mm	25 mm	37.5 mm	65 mm	
End of measuring range	17 mm	23 mm	30 mm	50 mm	90 mm	
Linearity <sup>[1]</sup>	< ±1 μm	< ±1.2 μm	< ±2 μm	< ±5 μm	< ±10 μm	
	< ±0.05 % FSO	< ±0.02 % FSO	< ±0.02 % FSO	< ±0.02 % FSO	< ±0.02 % FSO	
Repeatability <sup>[2]</sup>	< 0.1 μm	< 0.25 μm	< 0.4 μm	< 0.8 μm	< 1.6 μm	
Light spot diameter <sup>[3]</sup>	SMR	55 x 480 μm	100 x 600 μm	125 x 730 μm	210 x 950 μm	235 μm x 1280 μm
	MMR	40 x 460 μm	50 x 565 μm	55 x 690 μm	80 x 970 μm	125 μm x 1500 μm
	EMR	55 x 440 μm	100 x 525 μm	125 x 660 μm	220 x 1000 μm	325 μm x 1740 μm
	smallest Ø	40 x 460 μm with 16 mm	50 x 565 μm with 20 mm	55 x 690 μm with 25 mm	80 x 970 μm with 37.5 mm	115 x 1450 μm with 59 mm
Permissible ambient light	50,000 lx					

<sup>[1]</sup> Related to digital output; FSO = Full Scale Output

The specified data apply to white, diffuse reflecting surfaces (Micro-Epsilon reference ceramic for ILD sensors)

<sup>[2]</sup> Typical value with measurements at 4 kHz and median 9

<sup>[3]</sup> ±10 %; SMR = Start of measuring range; MMR = Mid of measuring range; EMR = End of measuring range  
Light spot diameter with line-shaped laser determined based on the emulated 90/10 knife-edge method

# Dimensions

## optoNCDT 1900

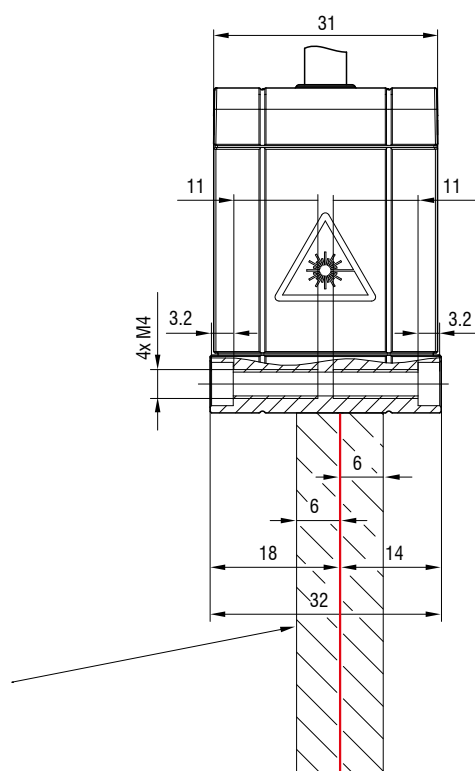
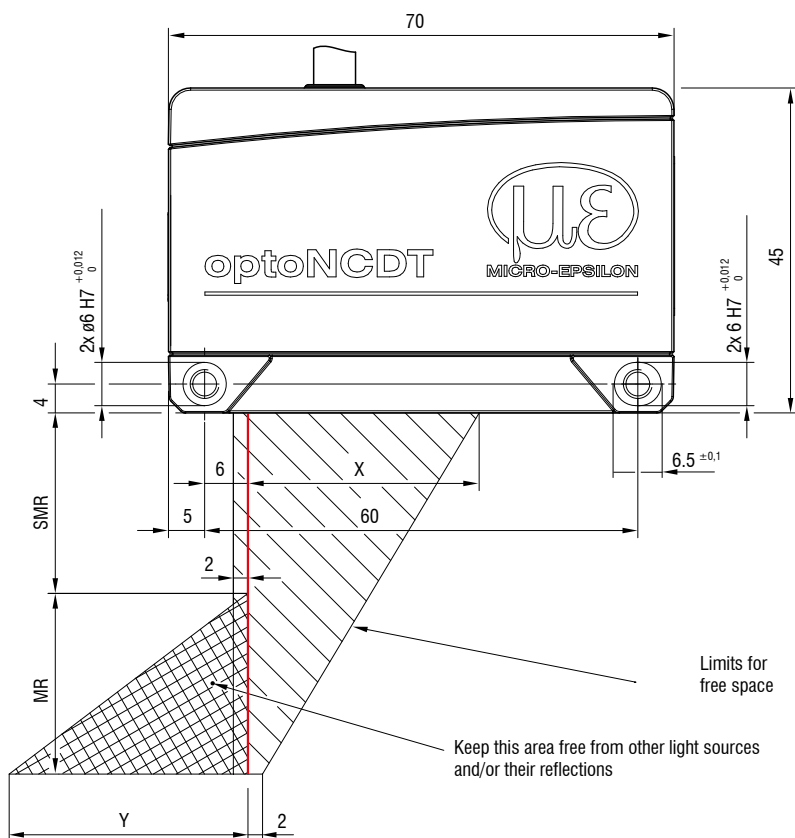

MR	SMR	X	Y
2	15	23	3
6	17	27	9
10	20	33	14
25	25	33	33
50	40	36	45
100	50	37	75
200	60	39	130
500	100	43	215

(Dimensions in mm, not to scale)

MR = measuring range; SMR = start of measuring range

MMR = mid of measuring range; EMR = end of measuring range

### Connector (sensor side)

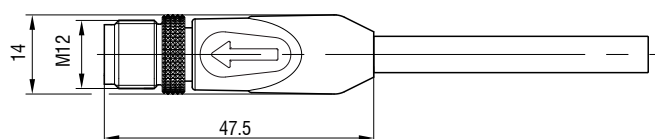

## Installation options

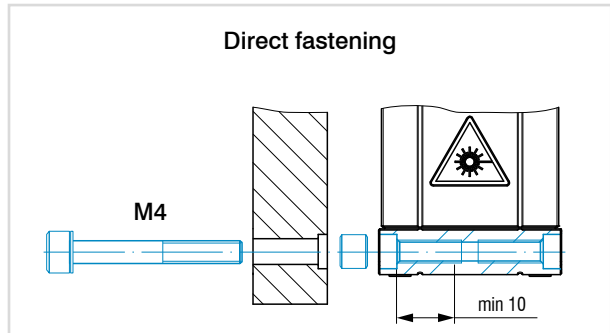
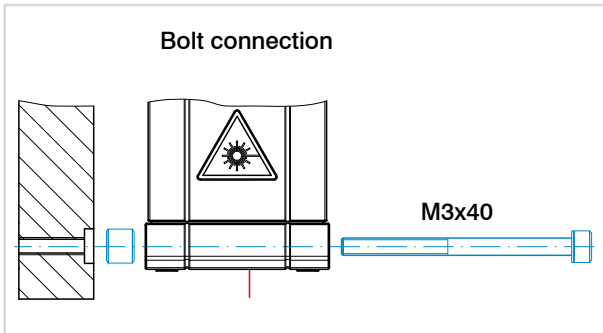

## Accessories for optoNCDT 1900/1910

### Power supply unit

PS2020 (power supply 24 V / 2.5 A, input 100 - 240 VAC, output 24 VDC / 2.5 A, mounting onto symmetrical standard rail 35 mm x 7.5 mm, DIN 50022)

### Protective film

Transparent protective film 52 x 15 mm for ILD1900

### Protective housings

with air purge and cooling, see page 62

## Scope of supply

- 1 Sensor ILD1900/1910
- 1 Assembly instructions
- 1 Calibration protocol
- Accessories (2 pc. centering sleeves, 2 pc. M3 x 40)

## Article designation



ILD1900-	6	LL	CL3B	EtherCAT
				<b>Interface</b> No indication: RS422, current, voltage (standard) integrated fieldbus: EtherCAT, EtherNet/IP, PROFINET
				<b>Laser class</b> No indication: class 2 (standard) 3B: on request 3R: on request
				<b>Laser type</b> No indication: Red laser point (standard) LL: Laser Line
Measuring range in mm				
<b>Series</b>				
ILD1900: Laser displacement sensor for Advanced Automation				

# Connection possibilities

## optoNCDT 1900







### Connection possibilities for sensors with integrated cables

Cable diameter: 5.80 ±0.2 mm  
 Drag chain: yes  
 Robot: no  
 Temperature range: -25 ... 80 °C (moving)  
 -40 ... 80 °C (not moving)  
 Bending radius: > 30 mm (fixed installation)  
 > 75 mm (dynamic)

Sensor	Cables	Type	Connection possibilities and accessories	
LD1900-xx ILD1900-xxLL ILD1910-xx	Integrated cable length 3 m	Open ends	<b>Supply voltage connection</b> Power supply unit PS2020	
			<b>Interface module of RS422 to USB</b> IF2001/USB IC2001/USB	
			<b>Interface module for Industrial Ethernet connection</b> IF2035-PROFINET IF2035-EIP IF2035-EtherCAT	

### Drag-chain suitable connection cables for sensors with pigtail



Cable diameter: 6.7 ±0.2 mm  
 Drag chain: yes  
 Robot: no  
 Temperature range: -25 ... 80 °C (moving) (up to +105 °C for max. 3000 hrs)  
 -40 ... 80 °C (not moving)  
 Bending radius: > 34 mm (fixed installation)  
 > 67 mm (dynamic)  
 > 81 mm (drag chain)

Sensor	Cables	Type	Connection possibilities and accessories	
ILD1900-xx ILD1900-xxLL ILD1910-xx	<b>Extension cable pigtail</b> Length 3 m / 6 m / 9 m / 15 m <i>Art. no. Designation</i> 29011218 PC1900-3/OE 29011219 PC1900-6/OE 29011220 PC1900-9/OE 29011221 PC1900-15/OE	Open ends	<b>Connection supply voltage</b> PS2020	
			<b>Interface module of RS422 to USB</b> IF2001/USB IC2001/USB	
			<b>Interface module for Industrial Ethernet connection</b> IF2035-PROFINET IF2035-EIP IF2035-EtherCAT	
			<b>Interface card for synchronous data acquisition</b> IF2008PCIe / IF2008E	
	<b>Adapter cable for PC interface card</b> Length 3 m / 6 m / 9 m / 15 m <i>Art. no. Designation</i> 29011316 PC1900-3/IF2008 PCIE 29011317 PC1900-6/IF2008 PCIE 29011318 PC1900-9/IF2008 PCIE 29011319 PC1900-15/IF2008 PCIE	Sub-D	<b>4-fold interface module from RS422 to USB</b> IF2004/USB	
	<b>Adapter cable for sensor calculation</b> Length 3 m / 6 m / 9 m / 15 m <i>Art. no. Designation</i> 29011320 PC1900-3/C-Box 29011321 PC1900-6/C-Box 29011322 PC1900-9/C-Box 29011323 PC1900-15/C-Box	Sub-D	<b>Controller for D/A conversion and evaluation of up to 2 sensor signals</b> Dual Processing Unit	
	<b>Adapter cable for sensor calculation</b> Length 2 m <i>Art. no. Designation</i> 29011326 PCE1900-3/M12	M12	<b>Interface module for Ethernet connection of up to 8 sensors</b> IF2008/ETH	



## Robot-suitable connection cables

Cable diameter:	approx. 7.3 mm
Drag chain:	no
Robot:	yes
Temperature range:	-40 ... 90 °C (moving) -50 ... 90 °C (not moving)
Bending radius:	> 37 mm (fixed installation) > 73 mm (dynamic)

Sensor	Cables	Type	Connection possibilities and accessories
LD1900-xx ILD1900-xxLL  ILD1910-xx	<b>Extension cable pigtail</b> Length 3 m / 6 m / 9 m / 15 m <i>Art. no.      Designation</i> 29011404      PC1900R-3/OE 29011405      PC1900R-6/OE 29011406      PC1900R-9/OE 29011407      PC1900R-15/OE	Open ends	<b>Connection supply voltage</b> PS2020 
			<b>Interface module of RS422 to USB</b> IF2001/USB IC2001/USB 
			<b>Interface module for Industrial Ethernet connection</b> IF2035-PROFINET IF2035-EIP IF2035-EtherCAT 

## Connection cables for sensors with integrated Industrial Ethernet interface



Cable diameter:	7.5 ±0.2 mm
Drag chain:	yes
Robot:	no
Temperature range:	-40 ... 90 °C (moving) -50 ... 90 °C (not moving)
Bending radius:	> 38 mm (fixed installation) > 75 mm (dynamic)

Sensor	Cables	Type	Connection possibilities and accessories
ILD1900-xx-PROFINET* ILD1900-xxLL-PROFINET*	<b>Connection cables PoE, laser On/Off hardware</b> Length 3 m / 6 m / 9 m / 15 m <i>Art. no.      Designation</i> 29011332      PC1900-IE-3/OE-RJ45 29011333      PC1900-IE-6/OE-RJ45 29011334      PC1900-IE-9/OE-RJ45 29011444      PC1900-IE-15/OE-RJ45	Open ends & RJ45	<b>Signal / Supply PoE</b> optional: PoE Switch 
ILD1900-xx-EtherCAT ILD1900-xxLL-EtherCAT ILD1900-xx-EtherNet/IP ILD1900-xxLL-EtherNet/IP			
ILD1900-xx-EtherCAT ILD1900-xxLL-EtherCAT ILD1900-xx-EtherNet/IP ILD1900-xxLL-EtherNet/IP	<b>Connection cables PoE, laser On/Off Software</b> Length 3 m / 6 m / 9 m / 15 m <i>Art. no.      Designation</i> 29011338      PC1900-IE-3/RJ45 29011355      PC1900-IE-6/RJ45 29011356      PC1900-IE-9/RJ45 29011445      PC1900-IE-15/RJ45	RJ45	

\*PoE not possible with PROFINET

## Other cables

Cable diameter:	6.7 mm
Drag chain:	yes
Robot:	no
Temperature range:	-40 ... 80 °C
Bending radius:	> 27 mm (fixed installation) > 51 mm (dynamic)

Input	Cables	Type	Connection possibilities and accessories
2 x Sub-D  (PC1900-x/ IF2008 PCIE)	<b>Adapter cable for the connection of two sensors per Sub-D connector</b> Length 0.1 m <i>Art. no.      Designation</i> 2901528      IF2008-Y-adapter cable 	Sub-D	<b>Interface card for synchronous data acquisition</b> IF2008PCle / IF2008E 
			<b>4-fold USB converter &amp; parameter setting</b> IF2004/USB 



**IF2035: Interface module for Industrial Ethernet connection**

- Connection of RS422 or RS485 interfaces to PROFINET / Ethernet/IP / EtherCAT
- Synchronization output for RS422 sensors
- 2 network connections for different network topologies
- Data rate up to 4 MBaud
- 4-fold oversampling (with EtherCAT)
- Ideal for confined spaces due to a compact housing and DIN rail mounting

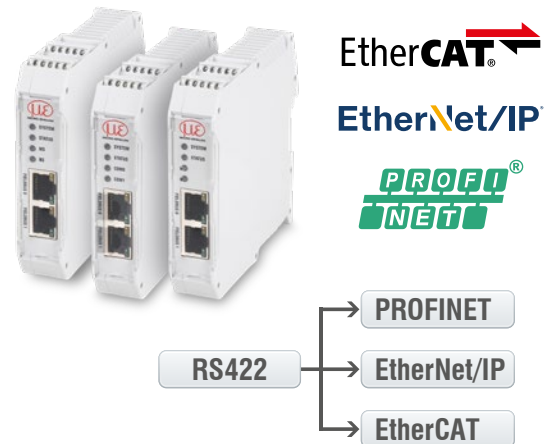

**IF2008PCIe/IF2008E: Interface card for synchronous data acquisition**

- IF2008PCIe - Basic PCB: 4 digital signals and 2 encoders
- IF2008E - Expansion board: 2x digital signals, 2x analog signals and 8x I/O signals
- Absolutely synchronous data acquisition for multi-channel applications (e.g. for planarity or thickness measurement)

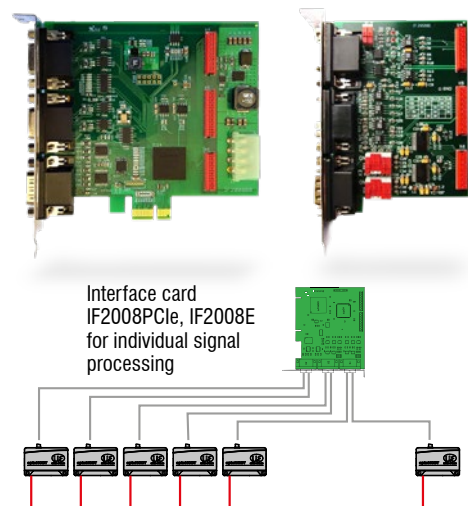

**Dual Processing Unit: Controller for D/A conversion and evaluation of up to 2 sensor signals**

- Fast D/A conversion (16 bit, with a maximum of 100 kHz) of 2 digital input signals or calculation of 2 digital sensor signals
- Averaging functions and calculation of thickness, step, diameter, ovality and radial run out
- Trigger input
- Multi-function output
- Measurement value output via Ethernet, USB, analog output 4 ... 20 mA/0 ... 5 V / 0 ... 10 V /  $\pm 5$  V /  $\pm 10$  V (scalable via web interface)
- 2x switching outputs for sensor or Dual Processing Unit status
- Parallel data output via three output interfaces
- Two filter possibilities
- Post-linearization of measured values or calculated values
- Easy parameter setting via web interface (controller and sensors)



**IF2008/ETH: Interface module for Ethernet connection of up to 8 sensors**

- Integration of eight sensors or encoders with RS422 interface in Ethernet network
- Four programmable switching in-/outputs (TTL and HTL logic)
- Fast data acquisition and output up to 200 kHz
- Simple parameter set up via web interface



**IC2001/USB Single-channel converter cable RS422/USB**

- Conversion from RS422 to USB
- 5-core interface cable without outer shield
- Easy sensor connection via USB
- Supports baud rates from 9.6 kBaud to 1 MBaud
- Ideal for integration into plant and machinery



**IF2001/USB: Interface module from RS422 to USB**

- Conversion from RS422 to USB
- Signals and functions such as laser on/off, switch signals and function output
- Supports baud rates from 9.6 kBaud to 12 MBaud
- Robust aluminum housing
- Easy sensor connection via screw terminals (plug and play)
- Parameter setting (converter and sensors) via software



**IF2004/USB: 4-fold interface module from RS422 to USB**





- Conversion of 4 digital signals (RS422) to USB
- 4x trigger inputs, 1x trigger output
- Synchronous data acquisition
- Parameter setting (converter and sensors) via software



Connection of 4 sensors via IF2008-Y-adapter cable

# Protective housings for demanding environments

**opto**NCDT

SGH & SGHF models				SGHF-HT model
Protective housing Size S		Protective housing Size M		
SGH	SGHF	SGH	SGHF	
				
(140 x 140 x 71 mm)		(180 x 140 x 71 mm)		(260 x 180 x 154 mm)
Water-resistant housing protects the sensor from solvents and detergents.	Ideal with high ambient temperatures. The integrated air cooling of the housing offers optimum protection for the sensor.	Water-resistant housing protects the sensor from solvents and detergents.	Ideal with high ambient temperatures. The integrated air cooling of the housing offers optimum protection for the sensor.	Water-cooled protective housing with window and compressed-air connection for measurement tasks in ambient temperatures up to 200 °C. Maximum temperature of cooling water T(max) = 10 °C Minimum water flow rate Q(min) = 3 liters/min
Size S suitable for ILD1750-20BL ILD1750-200BL ILD2300-2 / -2LL / -2BL ILD2300-5 / -5BL ILD2300-10 / -10LL / -10BL ILD2300-20 / -20LL ILD2300-50 / -50LL ILD2300-100		Size M suitable for ILD1750-500BL ILD1750-750BL ILD2300-200 ILD2300-300 ILD2310-10 ILD2310-20 ILD2310-40		Suitable for ILD1710-50 / -50BL ILD1710-1000 / -1000BL ILD1750-500BL ILD1750-750BL ILD2300-200 ILD2300-300 ILD2310-10 ILD2310-20 ILD2310-40 ILD2310-50BL

Protective housing SGHF ILD1900

Compact protective housing which is simply attached to the sensor. The protective housing has an air purge for cleaning the protective windows. It also cools the sensor.
Suitable for ILD1900-6 / -6LL ILD1900-10 / -10LL ILD1900-25 / -25LL ILD1900-50 / -50LL ILD1900-100 ILD1900-200 ILD1900-500

## sensorTOOL

The Micro-Epsilon sensorTOOL is a powerful software that is used to operate one or more optoNCDT sensors. The sensorTOOL can be used to access the sensor connected to the PC, display its complete data stream and save it in a file (in Excel-compatible CSV format). The sensor is configured via its web interface.

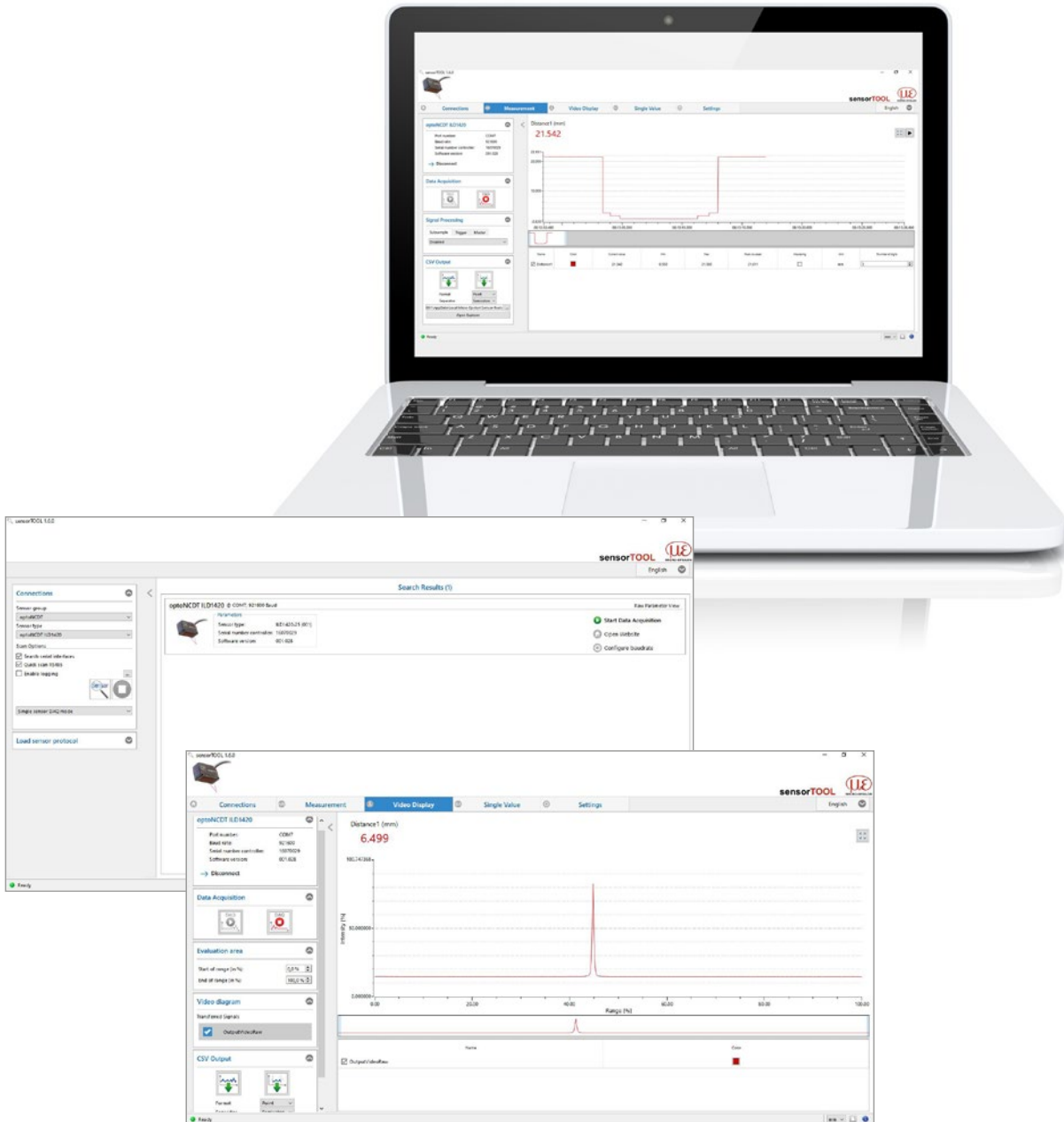

### Free download

All software tools, drivers and documented driver DLL for easy integration of the sensors into existing or internally-generated software are available free of charge under [www.micro-epsilon.de/download](http://www.micro-epsilon.de/download)

## Sensors and Systems from Micro-Epsilon



Sensors and systems for displacement, distance and position



Sensors and measurement devices for non-contact temperature measurement



Measuring and inspection systems for metal strips, plastics and rubber



Optical micrometers and fiber optics, measuring and test amplifiers



Color recognition sensors, LED analyzers and inline color spectrometers



3D measurement technology for dimensional testing and surface inspection