

Quick Manual
scanCONTROL

LLT82xx-25
LLT82xx-50
LLT82xx-100

LLT85xx-25
LLT85xx-50
LLT85xx-100

Contents

General	3
Symbols used	3
Warnings	3
Intended use	4
Proper environment	4
Notes on product marking.....	5
Glossary	5
Unpacking, included in delivery	5
Laser Safety	6
Mechanical fastening	8

Electrical connections, LEDs	11
Native Ethernet connection, PoE.....	11
Industrial Ethernet and IO connection.....	11
Native and Industrial Ethernet connection, IO.....	12
Connections, Pin assignment.....	12
Multifunction ports	13
Differential inputs and outputs.....	14
Digital switching inputs (single-ended)	14
Ethernet connection, standard connection to PC	15
LEDs	16
Laser activation	16
Quick start: Commissioning, software	17
Output of 2D profile data and/or 3D point clouds	18
Additional information	18
Basic functions of 3DInspect and scanCONTROL	19
Disclaimer	22
Decommissioning, disposal	22
Service, repair	23

MICRO-EPSILON
MESSTECHNIK
GmbH & Co. KG
Koenigbacher Str. 15

94496 Ortenburg / Germany

Tel. +49 (0) 8542 / 168-0
Fax +49 (0) 8542 / 168-90
info@micro-epsilon.com
www.micro-epsilon.com

You can find more information about the measuring system in the operating instructions. They are available online at:



<https://www.micro-epsilon.com/download-file/man--scanCONTROL-8x00--en.pdf>

General

Symbols used

The following symbols are used in this document:



Indicates a hazardous situation which, if not avoided, may result in minor or moderate injury.



Indicates a situation that may result in property damage if not avoided.



Indicates a user action.



Indicates a tip for users.

Measurement

Indicates hardware or a software button/menu.

Warnings



Connect the power supply and the display/output device according to the safety regulations for electrical equipment.

> Risk of injury, damage to or destruction of the sensor



The supply voltage must not exceed the specified limits.

> Damage to or destruction of the sensor

Avoid shocks and impacts to the sensor.

> Damage to or destruction of the sensor

Avoid constant exposure of the sensor to dust or splashes of water by taking suitable measures such as blowing off or using a protective housing. Avoid exposure of sensor to aggressive media (detergents, cooling emulsions).

> Damage to or destruction of the sensor

Do not touch the protective windows. Remove any fingerprints immediately using pure alcohol and a clean cotton cloth without leaving any streaks.

Protect the cable against damage.

> Failure of the measuring device

Only plug in or disconnect devices when disconnected from the power supply.

Intended use

- The sensor is designed for use in industrial and laboratory applications.
It is used for
 - Measuring profile
 - Measuring length
 - Monitoring quality and checking dimensions
- The sensor must only be operated within the values specified in the technical data.
- The sensor must be used in such a way that no persons are endangered or machines and other material goods are damaged in the event of malfunction or total failure of the sensor.
- Take additional precautions for safety and damage prevention in case of safety-related applications.

Proper environment

- Protection class
 - Sensor: IP67 ¹
(only applies in the case of connected output connectors and/or installed protective caps)
- Pollution degree: 2
- Temperature range
 - Operation: 0 ... +35 °C (+32 ... +95 °F) (without heat sink)
0 ... +45 °C (+32 ... +113 °F) (with optionally available passive heat sink)
Other application-specific cooling concepts must be evaluated individually.
 - Storage: -20 ... +70 °C (-4 ... -158 °F)
- Field of application: Indoors and outdoors
- Ambient pressure: Atmospheric pressure
- Humidity: 5 ... 95 % RH (non-condensing)
- Installation altitude: max. 2000 m above sea level

1) When an optional active cooling solution is installed, the IP rating is reduced to IP40.

Optical paths during operation are excluded from the protection class. Contamination of the paths causes impairment or failure of the function.

Use only shielded lines or original cables from the Optional accessories for the power supply connection or the outputs, see operating instructions.

Please also observe the notes on mounting and installation. Please refer to the operating instructions for additional information.

The sensor is dust-tight and protected against temporary immersion in water according to protection class IP67. The IP67 protection class specifies protection against dust and water only. Exposure to oil, vapor, and emulsions is not covered by this protection class and must be evaluated separately.

Notes on product marking

The product meets the requirements of CE and UKCA. All specifications and safety instructions described in the operating instructions must be observed.

Glossary

MR	Measuring range
SMR	Start of measuring range
EMR	End of measuring range
MMR	Mid of measuring range

Unpacking, included in delivery

- 1 sensor with integrated controller
- Calibration protocol
- Quick Manual
- 2 protective caps
- Blind plug with integrated safety interlock bridge (for PoE operation)
- 2 centering elements
- IEC laser warning labels

Optional accessories are listed in the operating instructions.

Laser Safety

The scanCONTROL 82xx / 85xx operates with a semiconductor laser with a wavelength of 520 nm (visible/green). The sensors fall within laser class 2M. The laser is operated on a pulsed mode, the maximum optical power is ≤ 20 mW.

The pulse frequency depends on the adjusted measuring rate (0 ... 20 kHz). The pulse duration of the peaks is regulated depending on the measuring rate and reflectivity of the target and can be 1 up to ∞ μ s.



Laser radiation. Irritation or injury of the eyes possible. Close your eyes or immediately turn away if the laser beam hits the eye.

- **i** Observe the national laser protection regulations.

When operating the sensors, the relevant regulations according to IEC 60825, Part 1 of 05/2014 and the applicable accident prevention regulations must be followed.

Laser of Class 2M are not subject to notification and a laser protection officer is not required.

The laser warning labels for Germany have already been attached. For other non German speaking countries, an IEC standard label is included in delivery and the versions valid for the user's country must be attached before the device is put into operation for the first time.

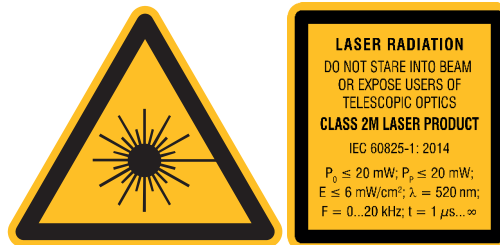

Laser warning sign and laser label, LLT8xxx-25, LLT8xxx-50, LLT8xxx-100

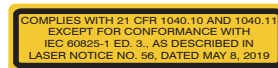

Only for USA

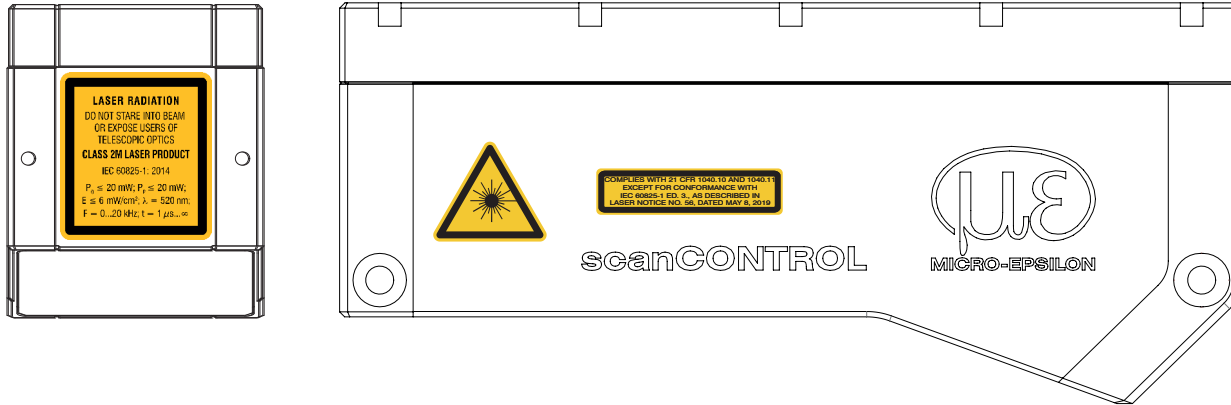

Sensor with laser Labels

i If both warning labels are covered over when the unit is installed, the user must ensure that supplementary labels are applied.

Mark the laser area recognizable and everlasting.

Operation of the laser is indicated visually by the LED on the sensor, see Operating Instructions, Chapter 3.

The housing of the optical sensors may only be opened by the manufacturer.

Please observe national regulations, e. g., Laser Notice No. 56 for the USA.

Mechanical fastening

➔ Mount the sensor according to the installation instructions.

ⓘ Ensure careful handling during installation and operation.

Through-bolt connection		
Through-bolt length	Screw	Torque
49 mm	M4 x ISO 4762-A2	1.9 Nm

Direct fastening		
Screw-in depth	Screw	Torque
min. 12 mm	M5 x ISO 4762-A2	2.5 Nm

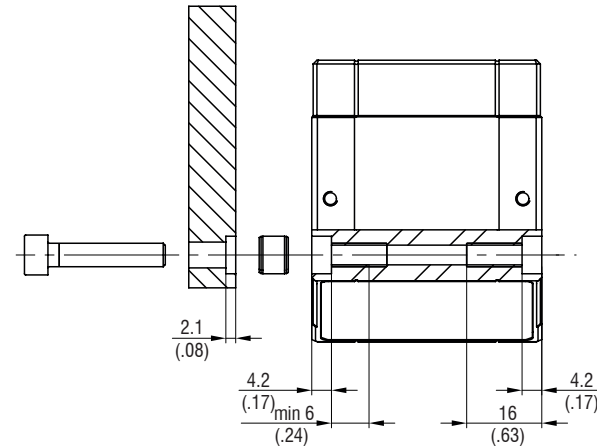
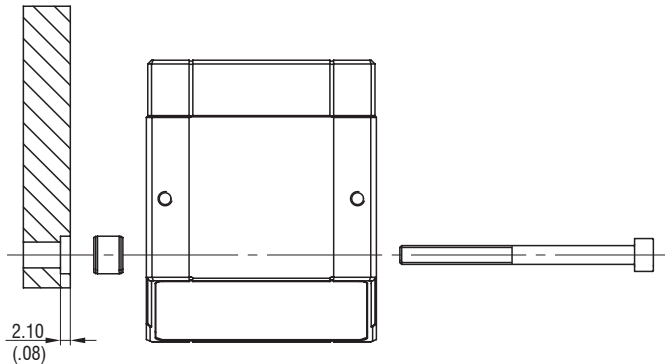

Mounting example with through-bolt connection

Through-bolt connection:

- 2 threaded holes
- with centering element:
- additionally 2 cylindrical counterbores 8H7
depth 1.8 ... 2 mm

Mounting example with direct fastening

Direct fastening:

- 2 bores \varnothing 5.5
- with centering element:
- additionally 2 cylindrical counterbores 8H7
depth 1.8 ... 2 mm

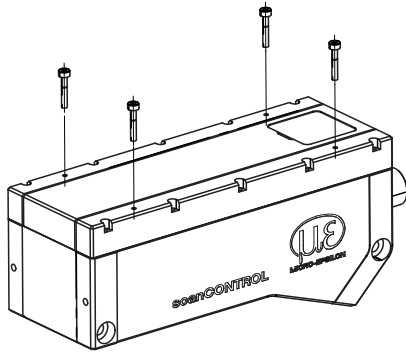

Mounting example: Top screw connection

Screw-in depth: max. 3.5 mm

Socket head cap screws: 4xISO 4762-A2 M2

Torque: 0.4 Nm

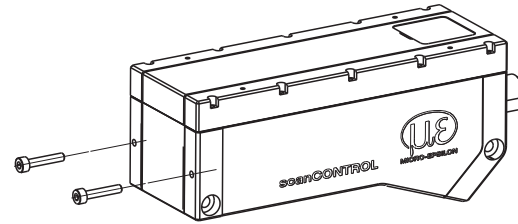

Mounting example: Lateral screw connection

Screw-in depth: max. 6 mm

Socket head cap screws: 4xISO 4762-A2 M3

Torque: 1.0 Nm

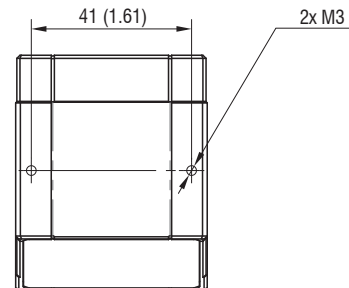
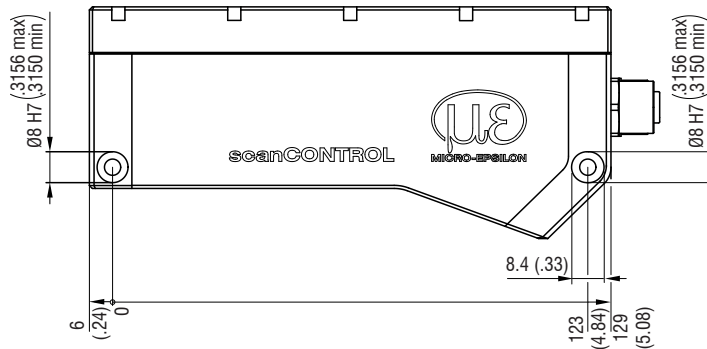

Dimensional drawing scanCONTROL 82xx / 85xx mounting holes, dimensions in mm (inches, rounded off)

scanCONTROL LLT82xx / LLT85xx

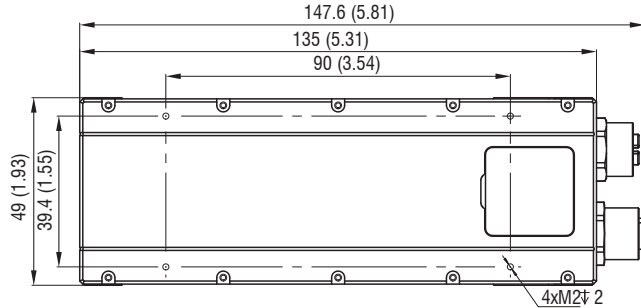

Dimensional drawing scanCONTROL 82xx / 85xx top view mounting hole, top screw connection, dimensions in mm (inches, rounded off)

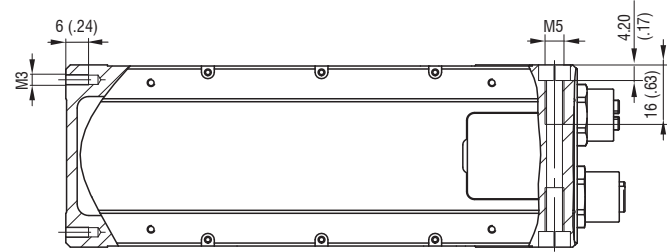

Dimensional drawing scanCONTROL 82xx / 85xx top view mounting hole, lateral screw connection, dimensions in mm (inches, rounded off)

		LLT8xxx-25	LLT8xxx-50	LLTxxx-100
Measuring range (z-axis)	SMR	75 (2.95)	83 (3.27)	112 (4.41)
	MMR	83 (3.27)	101 (3.98)	157 (6.18)
	EMR	91 (3.58)	119 (4.69)	202 (7.95)
Measuring range (x-axis)	SMR	24.2 (.95)	46.2 (1.82)	84 (3.31)
	MMR	25 (.98)	50 (1.97)	100 (3.94)
	EMR	25.8 (1.01)	53.6 (2.11)	115 (4.53)

Dimensions in mm (inches, rounded off)

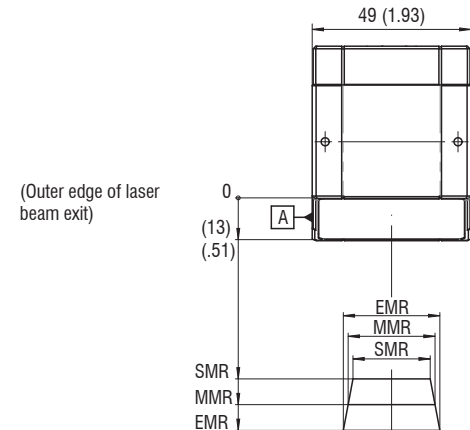

Electrical connections, LEDs

Native Ethernet connection, PoE

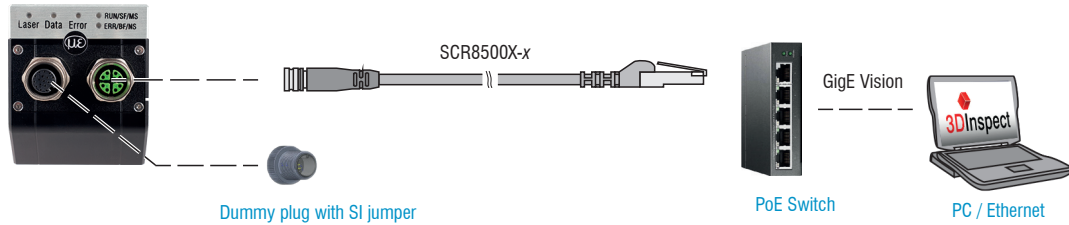

Connection example of Laser on/off via software and SI jumper

Industrial Ethernet and IO connection

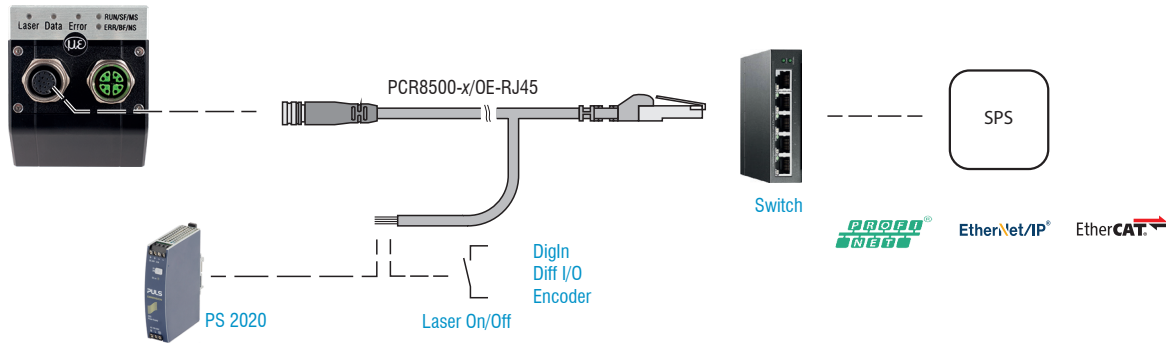

Connection example of supply via optional power supply unit, Laser on/off via hardware

Native and Industrial Ethernet connection, IO

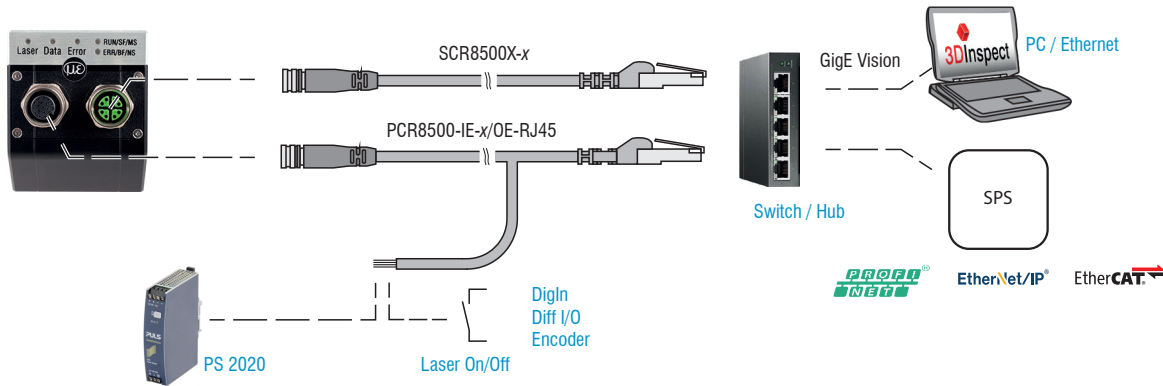

Connection example of supply for Industrial Ethernet and Native Ethernet

Connections, Pin assignment

1 multifunction port for PCR8500-x/OE-RJ45 multifunction cable (power supply, digital I/Os, sync, Industrial Ethernet)

2 Ethernet ports for SCR8500X-x Ethernet interface cable

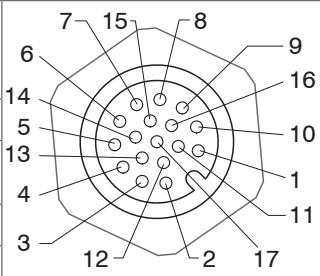
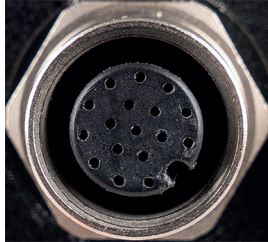

Multifunction ports

Pin	Designation	Wire color PCR8500-x/ OE-RJ45	Remarks		
1	GND	Blue	Power supply ground	 	
2	V ₊	Red	+11 V ... +30 V DC, nominal value 24 V, max. 15 W		
5	Diff I/O 1+	White	Differential input/output		
6	Diff I/O 1-	Brown	Differential input/output		
4	Laser_on/off	Violet			
7	Diff I/O 2+	Gray-pink	Differential input/output		
8	Diff I/O 2-	Red-blue	Differential input/output		
9	Dig In1	Green-black	Switching input 1 (single-ended)		
10	Dig In2	Yellow-black	Switching input 2 (single-ended)		
11	Dig In3	Gray-black	Switching input 3 (single-ended)		
12	Dig In4	Pink-black	Switching input 4 (single-ended)		
3	GND-In	Black	Ground Dig In		
15	RX Ethernet	White-green	Industrial Ethernet		
14	/RX Ethernet	Green	Industrial Ethernet		
17	TX Ethernet	White-orange	Industrial Ethernet		
16	/TX Ethernet	Orange	Industrial Ethernet		17-pin housing socket, pin side view
13	Ethernet shield	Eth shield	Industrial Ethernet		
Housing	Shield	Black	No galvanic connection to GND		

Pin assignment of multifunction port

For optimal performance, a dedicated 24V power supply suitable for measuring devices should be used to power scanCONTROL 82xx / 85xx sensors. To ensure optimum function and accuracy of the system, this power supply should not be used simultaneously for drives, contactors, or other devices with impulse-shaped interference sources.

Use a galvanically isolated power supply in accordance with LPS or NEC Class 2.

The supply voltage is protected against polarity reversal.

The cable shield is connected to the connector housing and should be connected to the PE protective conductor terminal of the power supply.

We recommend the optionally available multifunction cable PCR8500-x/OE-RJ45, see operating instructions.

Differential inputs and outputs

The differential inputs and outputs can be used for encoders, triggers, mode switching, and synchronization.

Pins 5 and 6 can be used with a differential encoder or for other differential I/Os.

Pins 7 and 8 can be used with a differential encoder, as sync I/O, or for other differential I/Os.

Digital switching inputs (single-ended)

The single-ended inputs can be used for encoder, trigger, and mode switching.

Pins 9 and 12 can be connected to up to 4 single-ended switching inputs.

Pins 10 to 12 can be connected to a single-ended encoder.

The signal levels for all switching inputs can be switched between LLL (low voltage, TTL logic) and HLL (high voltage, HTL logic) via software:

- LLL level: Low 0 V ... 0.8 V, High 2.4 V ... 5 V, internal pull-up/down 10 kOhm against 5 V/GND
- HLL level: Low 0 V ... 3 V, High 11 V ... 24 V (up to 30 V permissible), internal pull-up/down 10 kOhm against 24 V/GND
- Pulse duration: $\geq 5 \mu\text{s}$

Ethernet connection, standard connection to PC

8-pin Ethernet port (sensor side)			8 RJ45 connector	
Pin	Color SCR8500X-x	1000BaseT	Pin	Color control wire SCR8500X-x
1	White-orange	D1+	1	White-orange
2	Orange	D1-	2	Orange
3	White-green	D2+	3	White-green
4	Green	D2-	4	Blue
5	White-brown	D3+	5	White-blue
6	Brown	D3-	6	Green
7	White-blue	D4+	7	White-brown
8	Blue	D4-	8	Brown

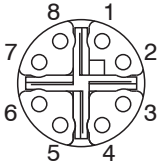
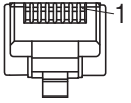
	<p>View: Solder side (cable) Screw connector X-coded</p>		<p>View: Pin side cable connector</p>
---	--	---	---

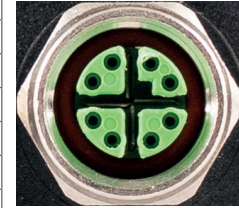

We recommend using the SCR8500X-x Ethernet interface cable for the Ethernet connection; see the operating instructions, Optional accessories.

- The sensor supports an automatic, sensor-specific IP address in the link-local network (169.254.x.x). No collision check is performed. This is also the default setting.
- The sensor supports DHCP. This setting is enabled by default and takes precedence over searching the link-local network.
- The scanCONTROL 82xx / 85xx sensor supports Power over Ethernet (IEEE 802.3at Class 4).

NOTICE

If the sensor is operated on a POE-enabled network connection/switch and the power supply via the multifunction socket is also used, these two power supplies must be galvanically isolated from each other.

> Damage to the sensor and/or the Ethernet card!

- A fixed IP address can be assigned.

➔ Use the 3DInspect program or sensorTOOL for network configuration.

These programs are available online at

<https://www.micro-epsilon.com/2d-3d-measurement/3d-sensors/3dinspect-software/>

<https://www.micro-epsilon.com/download/software/sensorTOOL.exe>

The operating instructions can be found online at

<https://www.micro-epsilon.com/fileadmin/download/manuals/man--3DInspect--en.pdf>

Additional software tool:

Pleora eBus Player <https://www.pleora.com/machine-vision-connectivity/ebus-player/>

Laser activation

The measurement laser on the sensor is switched via a dedicated input. This is advantageous when it comes to switching the sensor off for maintenance work or the like. The laser can also be switched off using software.

Power supply via multifunction port and power supply unit

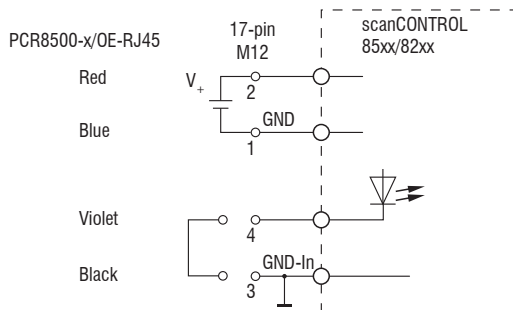

LEDs



LED Laser	Meaning
Yellow	Laser on

LED Data	Meaning
Green	Measurement is active
Green, flashing slowly	Data transmission running
Green, flashing briefly	Controller access

LED Error	Meaning
Red, flashing	Error code

Power supply via PoE

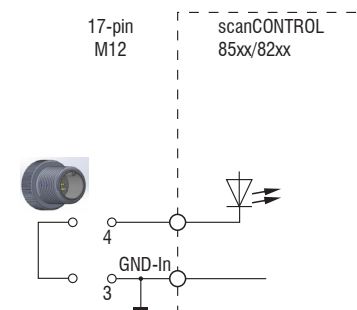

This function is integrated into all sensors.

In the event that no multifunction cable is connected during PoE operation, a dummy plug is included in the scope of delivery for bridging the external laser shutdown on the multifunction socket.

Details on pin assignment can be found in the operating instructions, chapter 5.

Quick start: Commissioning, software

➔ Connect the sensor and the PC using the optionally available SCR8500X-x Ethernet interface cable.

Power supply via multifunction port and power supply unit	Power supply via PoE
➔ Mount the sensor according to the installation instructions.	
➔ Install the 3DInspect software. This software is available online on the sensor's product page or in the Downloads section: https://www.micro-epsilon.com/2d-3d-measurement/3d-sensors/3dinspect-software/	
➔ Turn on the power supply.	---
➔ Launch 3DInspect.	
➔ Wait until the scanCONTROL sensor is recognized by the PC. This may take up to 30 seconds.	
<p>To operate the sensor via Ethernet, it may be necessary to adjust the IP settings on the PC or sensor. Recommendations for network settings can be found in the 3DInspect operating instructions. We recommend using a Gigabit Ethernet connection. For full data rate, jumbo frames must also be enabled on the network side.</p> <p>The connectors for Ethernet and the multifunction port are equipped with a threaded lock.</p> <p>➔ Loosen the screw before pulling the connector out of the port.</p>	

Output of 2D profile data and/or 3D point clouds

The profile data of scanCONTROL can be accessed in the following ways:

- GigE Vision and GenICam
This is a common interface standard in the field of industrial image processing (based on Gigabit Ethernet).
- Micro-Epsilon 3D Sensor SDK for fast application integration (C, C++, C#, Python, Linux, and others)

Please refer to the respective SDK documentation for further information on accessing the profile data.

Additional information

For more information, please refer to the online documentation at

<https://www.micro-epsilon.com/2d-3d-measurement/laser-profile-scanners/scancontrol-8xx0/>

Details on the individual programs can be found in the respective operating instructions or in the operating instructions for this sensor, Chapter 6.

The operating instructions can be found online at <https://www.micro-epsilon.com/2d-3d-measurement/>.

Basic functions of 3DInspect and scanCONTROL

- ➡ Open the 3DInspect program.
 - ➡ If the sensor is not detected automatically, click Options > Ethernet Configurator > Scan. Either adjust the Desired configuration or go to Suggest a configuration.
- Clicking on Apply to selected device applies the settings to the sensor. The 2D-View appears.
- ➡ Choose 2D as Data format. The first view is displayed.

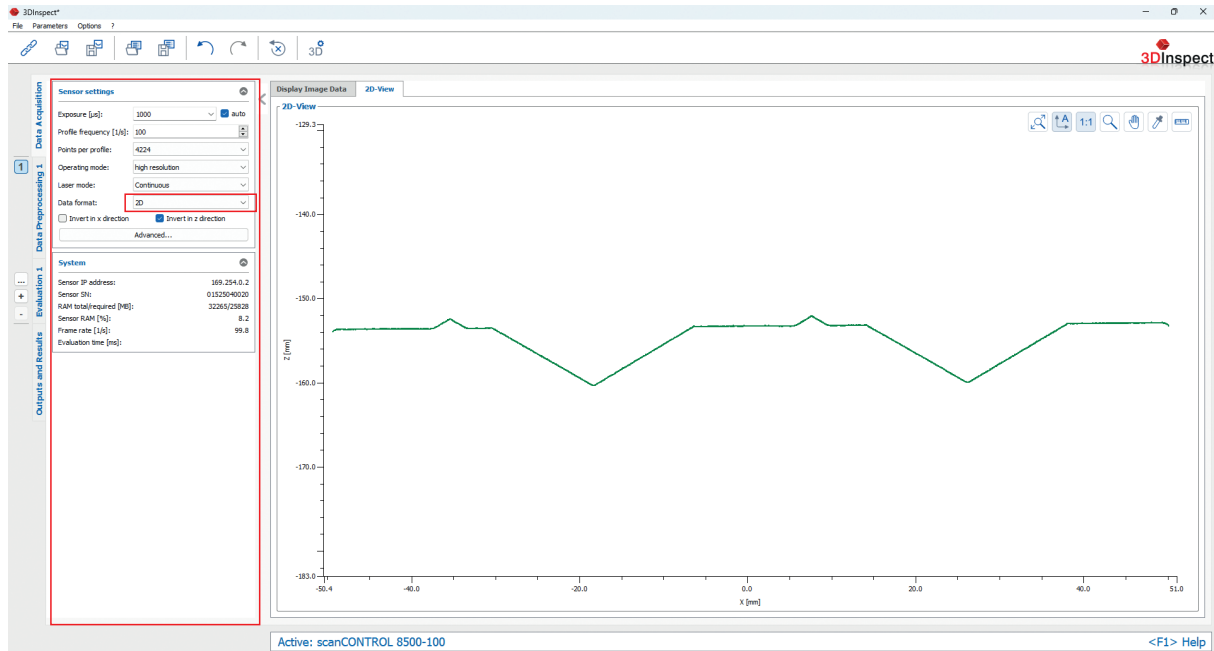

First display: 2D-View of the 3DInspect program

Basic sensor parameters can be adjusted as quick settings on the left side/column of the program.

Display Image Data shows the matrix image. A graphical selection area can also be set here. This allows the profile and data rate to be increased and interference to be suppressed.

The screenshot displays the 3DInspect software interface. On the left, there are two main sections: 'Data Acquisition' and 'System'. The 'Data Acquisition' section includes settings for Exposure (1000), Video image resolution (reduced), Laser mode (Continuous), and Signal gain (High). The 'System' section shows sensor details like IP address, S/N, RAM, and frame rate. The main window is titled 'Display Image Data' and shows a 'Sensor matrix' with a zoom factor of 34%. A red box highlights a 'Selection area' icon in the right sidebar. The status bar at the bottom indicates 'Active: scanCONTROL 8500-100' and '<F1> Help'.

Display Image Data view of the 3DInspect program

Further settings can be configured under *Advanced*. . . A comprehensive explanation of the adjustable parameters can be found in the operating instructions.

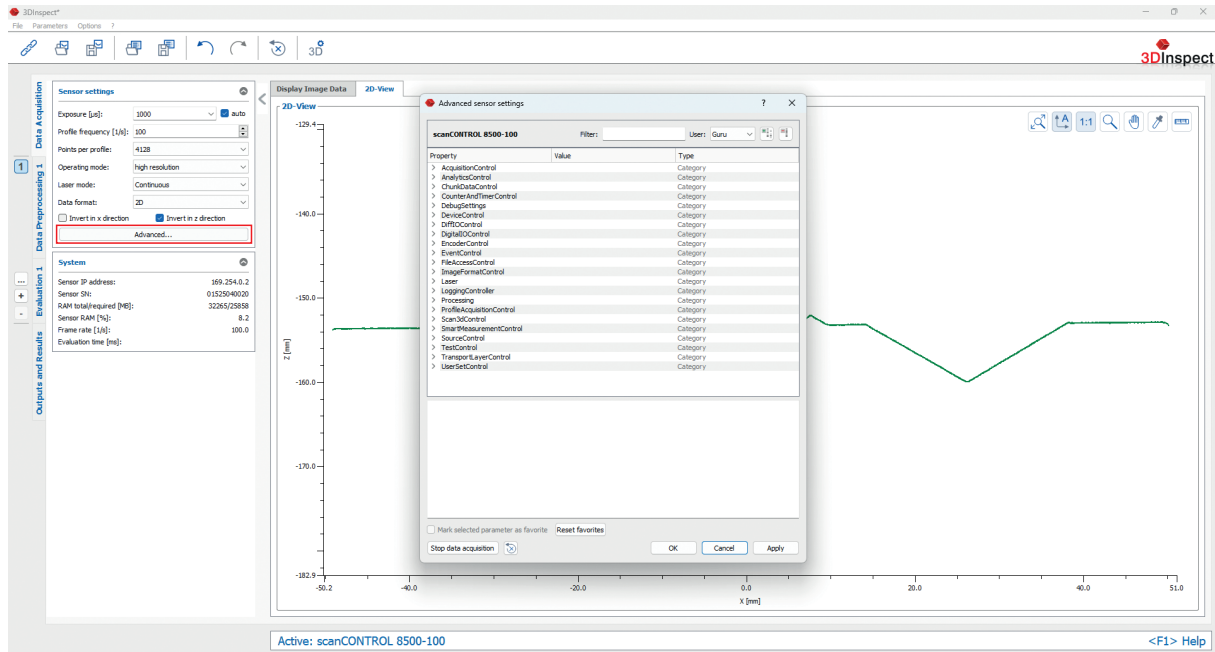

View 2D-View > Advanced. . . of the 3DInspect program

Information on generating 3D data, creating evaluation programs, and outputting measurement data can be found in the documentation for 3DInspect.

Disclaimer

All components of the device have been checked and tested for functionality in the factory. However, should any defects occur despite careful quality control, these shall be reported immediately to Micro-Epsilon or to your distributor / retailer.

Micro-Epsilon undertakes no liability whatsoever for damage, loss or costs caused by or related in any way to the product, in particular consequential damage, e.g., due to

- non-observance of these instructions/this manual,
- improper use or improper handling (in particular due to improper installation, commissioning, operation and maintenance) of the product,
- repairs or modifications by third parties,
- the use of force or other handling by unqualified persons.

This limitation of liability also applies to defects resulting from normal wear and tear (e.g., to wearing parts) and in the event of non-compliance with the specified maintenance intervals (if applicable).

Micro-Epsilon is exclusively responsible for repairs. It is not permitted to make unauthorized structural and / or technical modifications or alterations to the product. In the interest of further development, Micro-Epsilon reserves the right to modify the design or the firmware.

In addition, the General Terms of Business of Micro-Epsilon shall apply, which can be accessed under Legal details | Micro-Epsilon <https://www.micro-epsilon.com/legal-details/>.

Decommissioning, disposal

In order to avoid the release of environmentally harmful substances and to ensure the reuse of valuable raw materials, we draw your attention to the following regulations and obligations:

- Remove all cables from the sensor and/or controller.
- Dispose of the sensor and/or the controller, its components and accessories, as well as the packaging materials in compliance with the applicable country-specific waste treatment and disposal regulations of the region of use.
- You are obliged to comply with all relevant national laws and regulations.

For Germany / the EU, the following (disposal) instructions apply in particular:

- Waste equipment marked with a crossed garbage can must not be disposed of with normal industrial waste (e.g. residual waste can or the yellow recycling bin) and must be disposed of separately. This avoids hazards to the environment due to incorrect disposal and ensures proper recycling of the old appliances.
- A list of national laws and contacts in the EU member states can be found at https://ec.europa.eu/environment/topics/waste-and-recycling/waste-electrical-and-electronic-equipment-weee_en. Here you can inform yourself about the respective national collection and return points.
- Old devices can also be returned for disposal to Micro-Epsilon at the address given in the legal details at <https://www.micro-epsilon.com/legal-details/>.
- We would like to point out that you are responsible for deleting the measurement-specific and personal data on the old devices to be disposed of.
- Under the registration number WEEE Registration No. DE28605721, we are registered at the foundation Elektro-Altgeräte Register, Nordostpark 72, 90411 Nuremberg, as a manufacturer of electrical and/or electronic equipment.



Service, repair

If the sensor or sensor cables are defective:

- If possible, save the current settings in a parameter set to reload them into the sensor after the repair.
- Please send us the affected parts for repair or exchange.

If the cause of a fault cannot be clearly identified, please send the entire system incl. cables to:

MICRO-EPSILON Optronic
GmbH
Lessingstraße 21
01465 Dresden - Langebrück /
Germany
Tel. +49 (0) 35201 / 729-0
Fax +49 (0) 35201 / 729-90
info@micro-epsilon.com
www.micro-epsilon.com



MICRO-EPSILON MESSTECHNIK GmbH & Co. KG
Koenigbacher Str. 15 · 94496 Ortenburg / Germany
Tel. +49 (0) 8542 / 168-0 · Fax +49 (0) 8542 / 168-90
info@micro-epsilon.com · www.micro-epsilon.com
Your local contact: www.micro-epsilon.com/contact/worldwide/

X9691503-A022036HDR

© MICRO-EPSILON MESSTECHNIK